

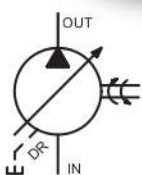

PV Axial piston pump

PV Series axial piston pump



nominal pressure:350 bar
max. pressure:420 bar

1. New type of swash plate and large servo piston with strong bias spring achieves fast response, reduce the noise due to active decompression of system at down stroke.
2. Nine pistons and new precompression technology (precompression filter volume) result in unbeaten low outlet flow pulsation.
3. Complete compensator program offers multiple controls.
4. Rigid and FEM-optimized body design for lowest noise level.
5. Thru drive for 100% nominal torque.
6. Pump combinations (multiple pumps) of same size and model and mounting interface for basically all metric or SAE mounting interfaces.
7. Wide application in automobile industrial, ships, forging machines, tire machines, injection molding machines, machine tools, special-purpose machine.

A
1
PV Axial piston pump

Quick Reference Data Chart

Size	Model	Pressure		Displacement		Pump Delivery (7 bar) 100 PSI				APPROX. Noise Levels			Speed		Weight KG (LB)
		nominal pressure	max. pressure	cm ³ /rev	in ³ /rev	1500 RPM		1800 RPM		dBA Full Flow and 1500 RPM			Max. RPM	Min. RPM	
						LPM	U.S. GPM	LPM	U.S. GPM	70 bar (1 KSI)	207 bar (3 KSI)	343 bar (5 KSI)			
1	PV016	350	420	16	0.98	24	6.3	28.8	7.6	56	60	68	2750	19 (42)	
	PV020			20	1.2	30	7.9	36	9.5						
	PV023			23	1.4	34.5	9.1	41.4	10.9						
	PV028			315	350	28	1.7	42	11						50.4
2	PV032	350	420	32	1.9	48	12.7	57.6	15.2	59	62	69	2400	30 (66)	
	PV040			40	2.4	60	15.9	72	19						
	PV046			46	2.8	69	18.2	82.2	21.9						
	PV056	280	350	56	3.41	84	22.1	100.8	26.6						
	PV065	250	315	65	3.96	97.5	25.7	117	30.9						
3	PV063	350	420	63	3.8	94.5	25	113.4	30	66	70	74	2100	60 (132)	
	PV071			71	4.3	107	28.3	128.7	34				2100		
	PV080			80	4.8	120	31.7	144	38				2000		
	PV092			92	5.6	138	36.5	165.6	43.8				1900		
	PV110	250	280	110	6.7	165	43.6	198	52.3				1900		
4	PV125	350	420	125	7.6	187.5	49.5	225	59.4	70	74	76	2200	90 (198)	
	PV140			140	8.5	210	55.5	252.1	66.6						
	PV180			180	11	270	71.3	324	85.6						71
	PV210	250	280	210	12.8	315	83.1	378	99.8				73		77
5	PV270	350	420	270	16.5	405	107	486	128.4	77	79	89	1800	172 (379)	

1. Outlet port is on the top, the pipe pressure should be less than 2 bar.
 2. The usage of max. Pressure for each circle never exceed 6 seconds. Please see the General Installation Information for hydraulic oil cleanliness manual.
 3. YEOSHE offers tandem pump or other types of pump connection. The mounting has Metric and SAE dimensions.



Type code for standard program

PV	063	GA	3	R	M	1	A	0	N	
1	2	3	4	5	6	7	8	9	10	11
Series	Size and displacement	Control device	Pressure adjusting	Rotation	Mounting	Threads	Thru drive & 2nd pump	Voltage	Seals	Design No.

E
4 Horse power for horse power control ("P" prefix)

Series

1	Axial piston pump variable displacement high pressure version	nominal pressure: 350 bar max. pressure : 420 bar	PV
---	---	--	----

Size and displacement

2	Code	016	020	023	028	032	040	046	056	065	063	071	080	092	110	125	140	180	210	270	
	Size	Body 1				Body 2				Body 3				Body 4				Body 5			
	Displacement	cm ³ /rev	16	20	23	28	32	40	46	56	65	63	71	80	92	110	125	140	180	210	270
		in ³ /rev	0.98	1.2	1.4	1.7	1.9	2.4	2.8	3.41	3.96	3.8	7.3	4.8	5.6	6.6	7.6	8.5	11	12.6	16.5

Control device

3	Standard pressure compensator	A0	
	None pressure compensator (fixed displacement) (pressure protection required)	LN	
	Electrical 2-stage flow compensator (pressure protection required)	LS	
	Fixed displacement 2-stage flow compensator (pressure protection required)	LC	
	Remote type		
	Remote pressure compensator with NG6 interface	GM	
	Remote pressure compensator + Relief valve	GA	
	Remote pressure compensator + Proportional pressure valve	GJ	
	Electrical unloading type		
	Remote pressure compensator + Electrical unloading	GR	
	Remote pressure compensator + 2-stage pressure control	GB	
	Remote pressure compensator + Electrical unloading + 2-stage pressure control	GC	
	Load-sensing type		
	Load-sensing compensator with NG6 interface	HM	
	Load-sensing compensator + Relief valve	HA	
	Load-sensing compensator + Proportional pressure valve	HJ	
	Load-sensing + Electrical unloading type		
	Load-sensing compensator + Electrical unloading	HR	
	Load-sensing compensator + 2-stage pressure control	HB	
	Load-sensing compensator + Electrical unloading + 2-stage pressure control	HC	
	Proportional pressure, flow type		
	Load-sensing compensator + Proportional flow valve + Relief valve	HQ	
	Load-sensing compensator + Proportional pressure valve + Proportional flow valve	HK	
	Horse power type		
	Horse power compensator with NG6 interface	PM	
	Horse power compensator + Relief valve	PA	
	Horse power compensator + Proportional pressure valve	PJ	
	Horse power compensator + Electrical unloading	PR	
	Horse power compensator + Electrical unloading+2-stage pressure control	PC	
	Horse power load-sensing compensator + Relief valve	PH	
Horse power load-sensing compensator + Proportional flow valve + Relief valve	PQ		
Horse power load-sensing compensator + Proportional pressure valve	PS		

Type code for standard program

PV	063	GA	3	R	M	1	A	0	N	
1	2	3	4	5	6	7	8	9	10	11
Series	Size and displacement	Control device	Pressure adjusting	Rotation	Mounting	Threads	Thru drive & 2nd pump	Voltage	Seals	Design No.

E
4 Horse power for horse power control ("P" prefix)

Pressure adjustment

4	10~140 bar (145~2030 PSI)	2
	35~250bar (507~3625 PSI)	3
	40~280bar (580~4060 PSI)	4
	50~315bar (725~4567 PSI)	5
	70~350bar (1015~5075 PSI)	6

Pressure range for each displacement:

		2	3	4	5	6
4	PV016~PV023	■	■	■	■	■
	PV028	■	■	■	-	-
	PV032~PV046	■	■	■	■	■
	PV056	■	■	■	-	-
	PV065	■	■	-	-	-
	PV063~PV092	■	■	■	■	■
	PV110	■	■	-	-	-
	PV125~PV180	■	■	■	■	■
	PV210	■	■	■	-	-
	PV270	■	■	■	■	■

Pressure range for each control device:

		2	3	4	5	6	
4	A0 Standard pressure compensator	■	■	■	■	■	
	LN None pressure compensator (fixed displacement) (pressure protection required)	■	■	■	■	■	
	LS Electrical 2-stage flow compensator (pressure protection required)	■	■	■	■	■	
	LC Fixed displacement 2-stage flow compensator (pressure protection required)	■	■	■	■	■	
	Remote type						
	GM Remote pressure compensator with NG6 interface	■	■	■	■	■	
	GA Remote pressure compensator + Relief valve	■	■	■	■	■	
	GJ Remote pressure compensator + Proportional pressure valve	■	■	-	-	-	
	Electrical unloading type						
	GR Remote pressure compensator + Electrical unloading	■	■	■	■	■	
	GB Remote pressure compensator + 2-stage pressure control	■	■	■	■	■	
	GC Remote pressure compensator + Electrical unloading + 2-stage pressure control	■	■	■	■	■	
	Load-sensing Type						
	HM Load-sensing compensator with NG6 interface	■	■	■	■	■	
	HA Load-sensing compensator + Relief valve	■	■	■	■	■	
HJ Load-sensing compensator + Proportional pressure valve	■	■	-	-	-		

■ = available - = on request ※ = standard type



Type code for standard program

PV	063	GA	3	R	M	1	A	0	N	
1	2	3	4	5	6	7	8	9	10	11
Series	Size and displacement	Control device	Pressure adjusting	Rotation	Mounting	Threads	Thru drive & 2nd pump	Voltage	Seals	Design No.

E	Horse power for horse power control ("P" prefix)
4	

Pressure range for each control device:

2 3 4 5 6

4	Load-sensing + Electrical unloading type				
	HR	Load-sensing compensator + Electrical unloading	<input checked="" type="checkbox"/>	<input checked="" type="checkbox"/>	<input checked="" type="checkbox"/>
	HB	Load-sensing compensator + 2-stage pressure control	<input checked="" type="checkbox"/>	<input checked="" type="checkbox"/>	<input checked="" type="checkbox"/>
	HC	Load-sensing compensator + Electrical unloading + 2-stage pressure control	<input checked="" type="checkbox"/>	<input checked="" type="checkbox"/>	<input checked="" type="checkbox"/>
	Proportional pressure, flow type				
	HQ	Load-sensing compensator + Proportional flow valve + Relief valve	<input checked="" type="checkbox"/>	<input checked="" type="checkbox"/>	<input checked="" type="checkbox"/>
	HK	Load-sensing compensator + Proportional pressure valve + Proportional flow valve	<input checked="" type="checkbox"/>	<input checked="" type="checkbox"/>	-
	Horse power type				
	PM	Horse power compensator with NG6 interface	<input checked="" type="checkbox"/>	<input checked="" type="checkbox"/>	<input checked="" type="checkbox"/>
	PA	Horse power compensator + Relief valve	<input checked="" type="checkbox"/>	<input checked="" type="checkbox"/>	<input checked="" type="checkbox"/>
	PJ	Horse power compensator + Proportional pressure valve	<input checked="" type="checkbox"/>	<input checked="" type="checkbox"/>	-
	PR	Horse power compensator + Relief valve + Electrical unloading	<input checked="" type="checkbox"/>	<input checked="" type="checkbox"/>	<input checked="" type="checkbox"/>
	PC	Horse power compensator + Electrical unloading +2-stage pressure control	<input checked="" type="checkbox"/>	<input checked="" type="checkbox"/>	<input checked="" type="checkbox"/>
	PH	Horse power load-sensing compensator + Relief valve	<input checked="" type="checkbox"/>	<input checked="" type="checkbox"/>	<input checked="" type="checkbox"/>
PQ	Horse power load-sensing compensator + Proportional flow valve + Relief valve	<input checked="" type="checkbox"/>	<input checked="" type="checkbox"/>	<input checked="" type="checkbox"/>	
PS	Horse power load-sensing compensator + Proportional pressure valve	<input checked="" type="checkbox"/>	<input checked="" type="checkbox"/>	-	

Pressure adjusting (Please following page A-34~36)

Displacement	Horse power
PV016~PV023,28	<input type="checkbox"/> A 3KW <input type="checkbox"/> B 4KW <input type="checkbox"/> C 5.5KW <input type="checkbox"/> D 7.5KW <input type="checkbox"/> E 11KW
PV032~PV046,56,65	<input type="checkbox"/> C 5.5KW <input type="checkbox"/> D 7.5KW <input type="checkbox"/> E 11KW <input type="checkbox"/> F 15KW <input type="checkbox"/> G 18.5KW <input type="checkbox"/> H 22KW
4 PV063~PV092,110	<input type="checkbox"/> E 11KW <input type="checkbox"/> F 15KW <input type="checkbox"/> G 18.5KW <input type="checkbox"/> H 22KW <input type="checkbox"/> I 30KW <input type="checkbox"/> J 37KW <input type="checkbox"/> K 45KW
PV125,140	<input type="checkbox"/> G 18.5KW <input type="checkbox"/> H 22KW <input type="checkbox"/> I 30KW <input type="checkbox"/> J 37KW <input type="checkbox"/> K 45KW <input type="checkbox"/> L 55KW
PV180,210	<input type="checkbox"/> H 22KW <input type="checkbox"/> I 30KW <input type="checkbox"/> J 37KW <input type="checkbox"/> K 45KW <input type="checkbox"/> L 55KW <input type="checkbox"/> M 75KW <input type="checkbox"/> N 90KW
PV270	<input type="checkbox"/> J 37KW <input type="checkbox"/> K 45KW <input type="checkbox"/> L 55KW <input type="checkbox"/> M 75KW <input type="checkbox"/> N 90KW <input type="checkbox"/> O 110KW <input type="checkbox"/> P 132KW

Rotation

5	Clockwise	R
	Counter clockwise	L

= available - = on request ✖ = standard type

Type code for standard program

PV	063	GA	3	R	M	1	A	0	N	
1	2	3	4	5	6	7	8	9	10	11
Series	Size and displacement	Control device	Pressure adjusting	Rotation	Mounting	Threads	Thru drive & 2nd pump	Voltage	Seals	Design No.

E	Horse power for horse power control ("P" prefix)
4	

Mounting

6	Metric	Parallel keyed	<input type="checkbox"/> M <input type="checkbox"/> R (A-44)	<input type="checkbox"/> M <input type="checkbox"/> R (A-52)	<input type="checkbox"/> M <input type="checkbox"/> R (A-60)	<input type="checkbox"/> M <input type="checkbox"/> R <input type="checkbox"/> Q (A-67)	<input type="checkbox"/> M <input type="checkbox"/> R (A-74)
		Splined	<input type="checkbox"/> K <input type="checkbox"/> S (A-44)	<input type="checkbox"/> K <input type="checkbox"/> S <input type="checkbox"/> P (A-52)	<input type="checkbox"/> K <input type="checkbox"/> S (A-60)	<input type="checkbox"/> K <input type="checkbox"/> S <input type="checkbox"/> P (A-67)	<input type="checkbox"/> K <input type="checkbox"/> S (A-74)
	Inch	Parallel keyed	<input type="checkbox"/> N <input type="checkbox"/> J (A-46)	<input type="checkbox"/> N <input type="checkbox"/> J (A-54)	<input type="checkbox"/> N <input type="checkbox"/> J (A-62)	<input type="checkbox"/> N <input type="checkbox"/> J <input type="checkbox"/> F (A-69)	<input type="checkbox"/> N <input type="checkbox"/> J (A-76)
		Splined	<input type="checkbox"/> D <input type="checkbox"/> U (A-46)	<input type="checkbox"/> D <input type="checkbox"/> U <input type="checkbox"/> G (A-54)	<input type="checkbox"/> D <input type="checkbox"/> U (A-62)	<input type="checkbox"/> D <input type="checkbox"/> U <input type="checkbox"/> G (A-69)	<input type="checkbox"/> D <input type="checkbox"/> U (A-76)

(Dimensions refer to dimension diagram)

Threads

7	BSPP (G)	<input type="checkbox"/> 1
	PT (RC)	<input type="checkbox"/> 2
	UNF (SAE)	<input type="checkbox"/> 3
	ISO 6149 (M)	<input type="checkbox"/> 7

※

Thru drive & 2nd pump

	Displacement	Code
8	PV016~PV270	<input type="checkbox"/> A Single pump <input type="checkbox"/> B Prepared for thru drive
	PV016~PV023,28	<input type="checkbox"/> C <input type="checkbox"/> D <input type="checkbox"/> E <input type="checkbox"/> I <input type="checkbox"/> J <input type="checkbox"/> K
	PV032~PV046,56,65	<input type="checkbox"/> D <input type="checkbox"/> E <input type="checkbox"/> F <input type="checkbox"/> I <input type="checkbox"/> J <input type="checkbox"/> K <input type="checkbox"/> L
	PV063~PV092,110	<input type="checkbox"/> D <input type="checkbox"/> E <input type="checkbox"/> F <input type="checkbox"/> G <input type="checkbox"/> I <input type="checkbox"/> J <input type="checkbox"/> K <input type="checkbox"/> L <input type="checkbox"/> M
	PV125~PV180,210	<input type="checkbox"/> D <input type="checkbox"/> E <input type="checkbox"/> F <input type="checkbox"/> G <input type="checkbox"/> J <input type="checkbox"/> K <input type="checkbox"/> L <input type="checkbox"/> M
	PV270	<input type="checkbox"/> D <input type="checkbox"/> E <input type="checkbox"/> F <input type="checkbox"/> G <input type="checkbox"/> H <input type="checkbox"/> J <input type="checkbox"/> K <input type="checkbox"/> L <input type="checkbox"/> M <input type="checkbox"/> N

Size

8	SAE AA, Ø50.8 mm	<input type="checkbox"/> C
	SAE A, Ø82.55 mm	<input type="checkbox"/> D
	SAE B, Ø101.6 mm	<input type="checkbox"/> E
	SAE C, Ø127 mm	<input type="checkbox"/> F
	SAE D, Ø152.4 mm	<input type="checkbox"/> G
	SAE E, Ø165.1 mm	<input type="checkbox"/> H
	Metric, Ø63 mm	<input type="checkbox"/> I
	Metric, Ø80 mm	<input type="checkbox"/> J
	Metric, Ø100 mm	<input type="checkbox"/> K
	Metric, Ø125 mm	<input type="checkbox"/> L
	Metric, Ø160 mm	<input type="checkbox"/> M
	Metric, Ø200 mm	<input type="checkbox"/> N

Other pumps are acceptable to order



Type code for standard program

A

6

PV Axial piston pump

PV	063	GA	3	R	M	1	A	0	N	
1	2	3	4	5	6	7	8	9	10	11
Series	Size and displacement	Control device	Pressure adjusting	Rotation	Mounting	Threads	Thru drive & 2nd pump	Voltage	Seals	Design No.

E	Horse power for horse power control ("P" prefix)
4	

Voltage

9	None	0
	AC100V (50/60HZ)	A
	AC110V (60HZ)	B
	AC200V (50/60HZ)	C
	AC220V (60HZ)	D
	DC 12V	E
	DC 24V	F

Seals

10	NBR	N	※
	VITON, FKM	V	
	Ethylen-propylene	E	

■ = available - = on request ※ = standard type

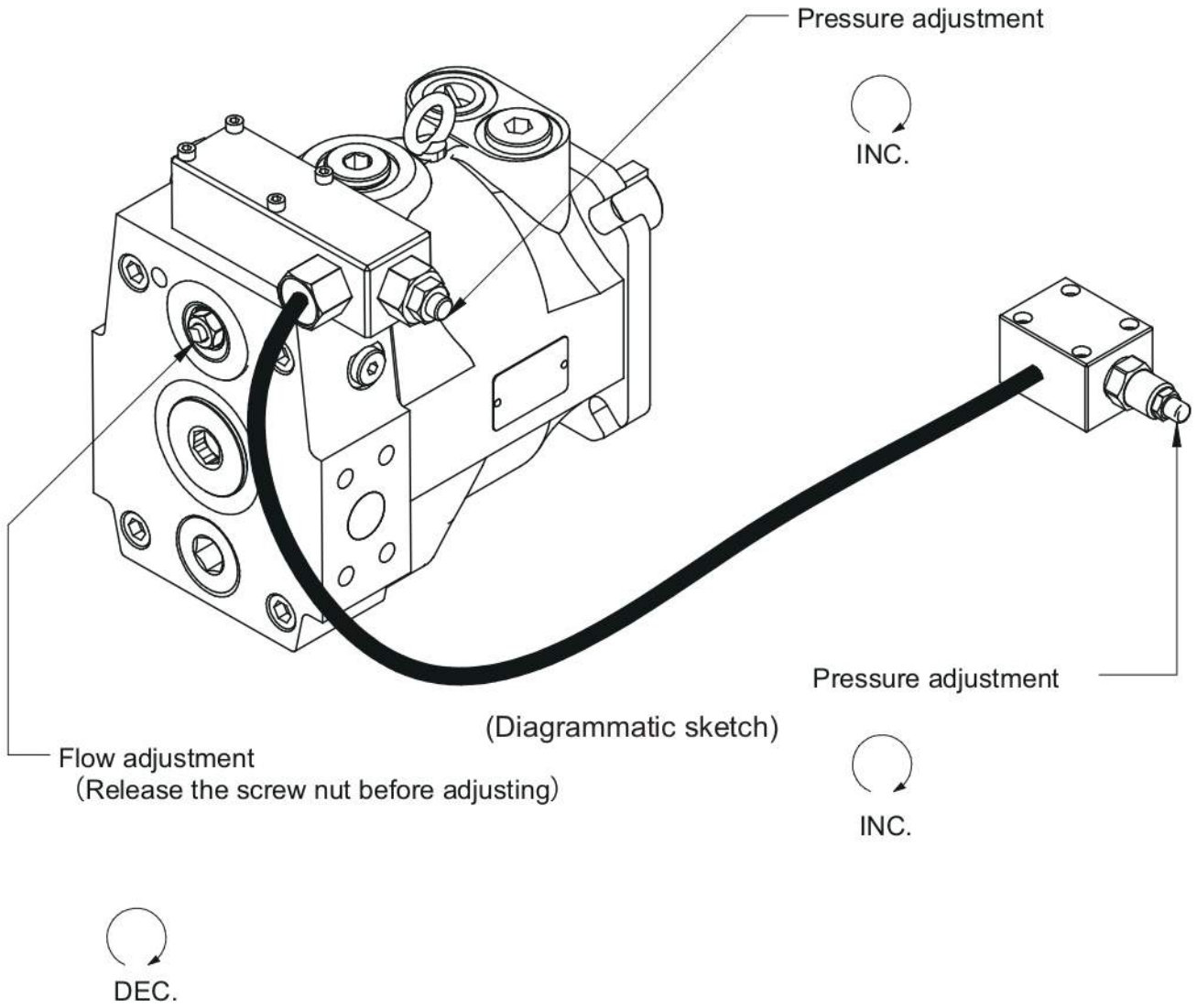



A0 Standard pressure compensator

A

8

PV Axial piston pump

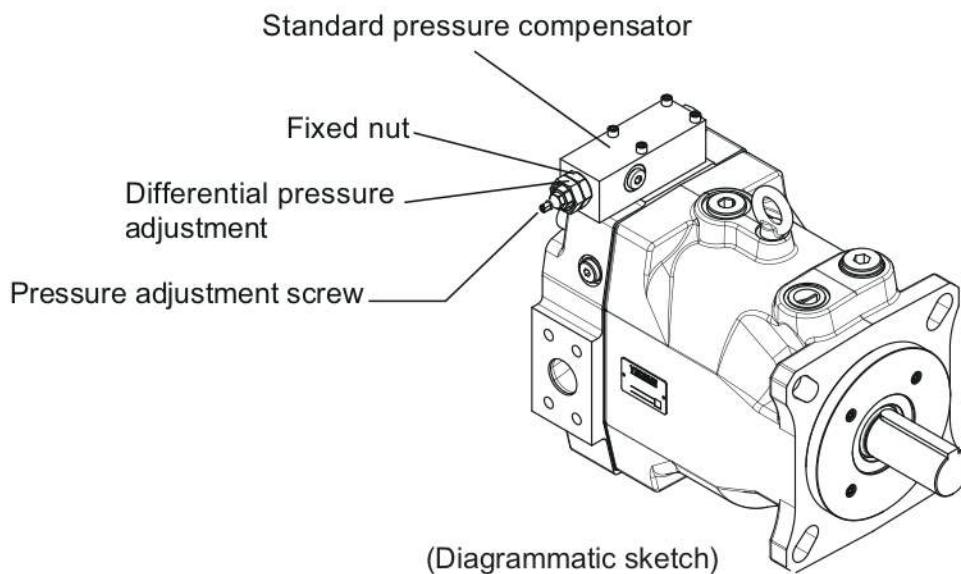

A0 Standard pressure compensator

The standard pressure compensator adjusts the pump displacement according to the actual need of the system in order to keep the pressure constant.

As long as the system pressure at outlet port P is lower than the set pressure (set as spring preload of the compensator spring) the working port A of the compensator valve is connected to the case drain and the piston area is unloaded. Bias spring and system pressure on the annulus area keep the pump at full displacement.

When the system pressure reaches the set pressure the compensator valve spool connects port P1 to A and builds up a pressure at the servo piston resulting in a downstroking of the pump.

The displacement of the pump is controlled in order to match the flow requirement of the system.

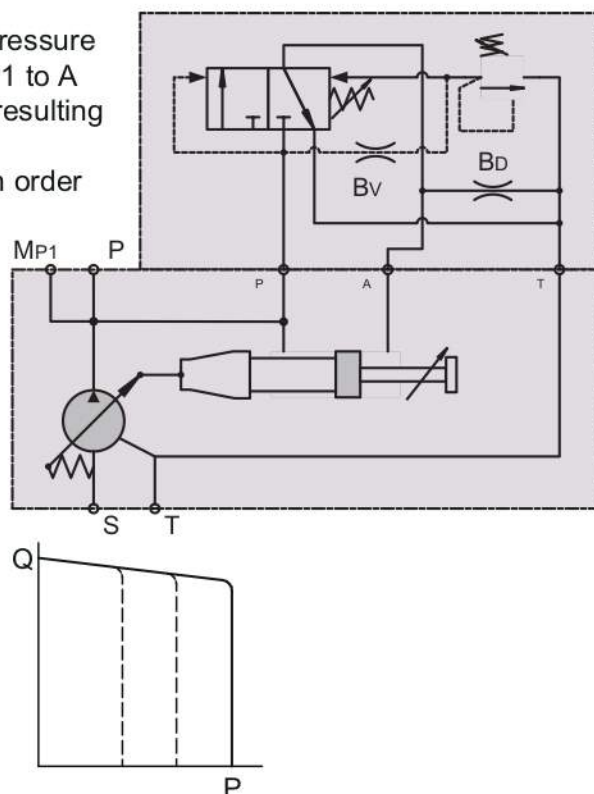

LN None pressure compensator (fixed displacement) (pressure protection required)

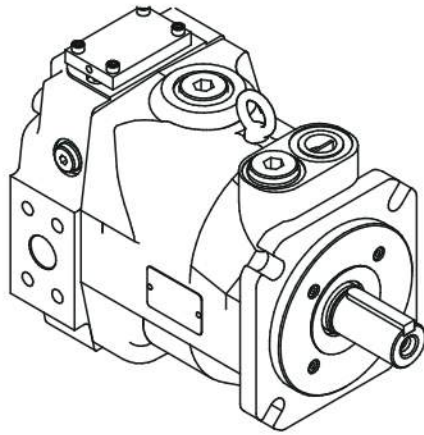

(Diagrammatic sketch)

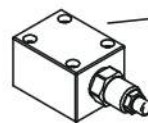

External pressure protection Relief valve(additional)

LN None pressure compensator
(fixed displacement) (pressure protection required)

By using the system under stable displacement and pressure situation, standard pressure compensator can be omitted which helps cost down.

Notice:

External pressure protection is necessarily added at port PM to limit the pressure; otherwise the system pressure will be over high .

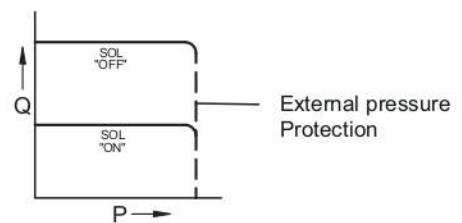
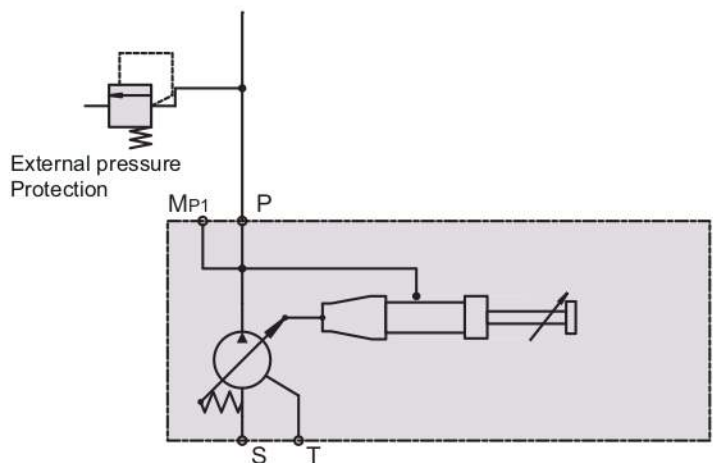



LS Electrical 2-stage flow compensator (pressure protection required)

A

10

PV Axial piston pump

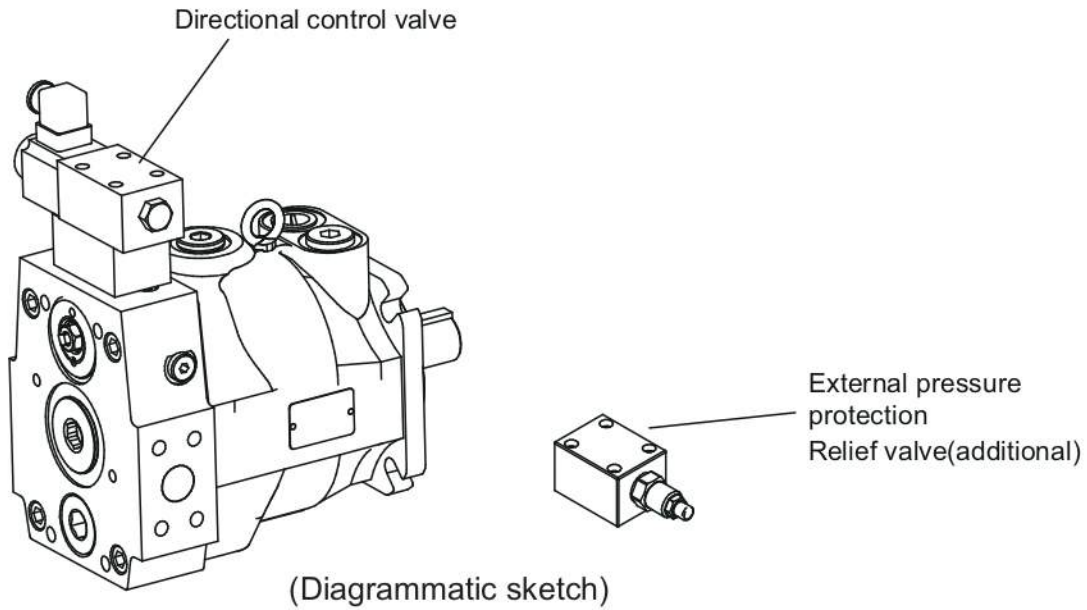

LS Electrical 2-stage flow compensator
(pressure protection required)

Control the hydraulic circuit change by using directional control valve.
LS control is applied to two-stage stroke and different speed system.

Notice:

External pressure protection is necessarily added at port PM to limit the pressure; otherwise the system pressure will be over high.

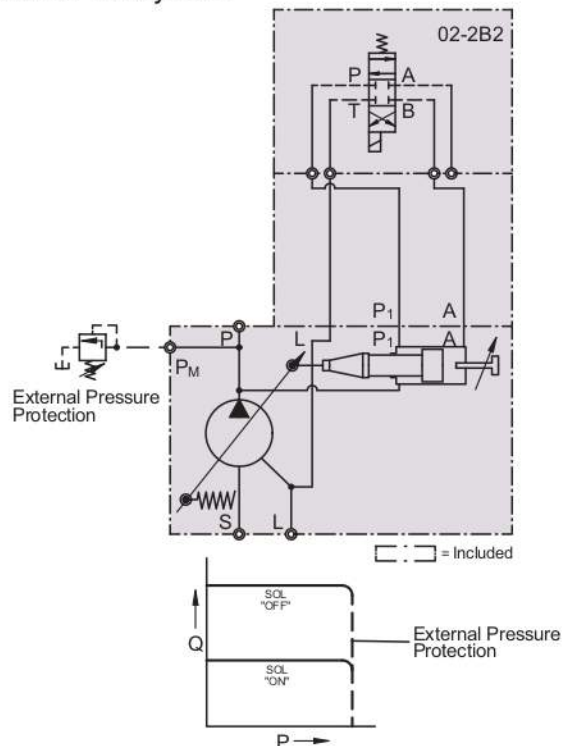

LC Fixed displacement 2-stage flow compensator **YEOSHE** (pressure protection required)

Fixed displacement 2-stage flow compensator
(pressure protection required)

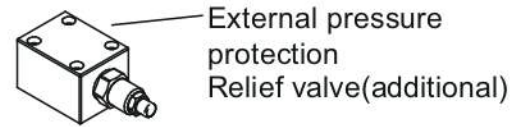
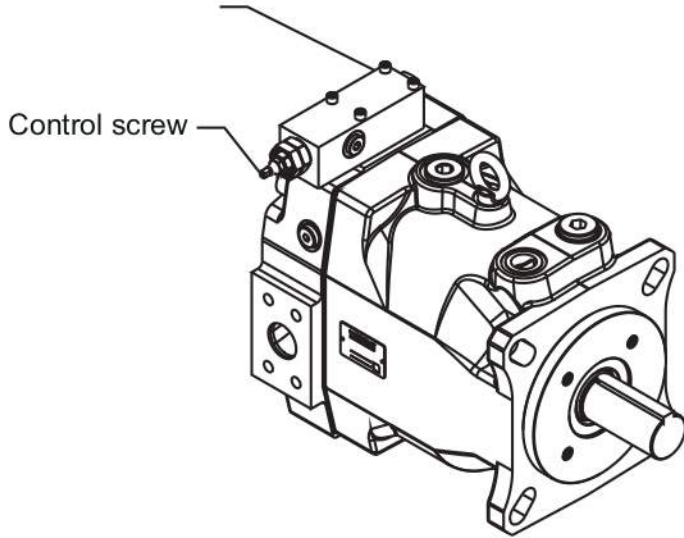

(Diagrammatic sketch)

LC Fixed displacement 2-stage flow compensator
(pressure protection required)

Control the hydraulic circuit change by using the system pressure setting to achieve the switch of big and small flow.

LS control is applied to two-stage stroke and different speed system.

Notice:

External pressure protection is necessarily added at port PM to limit the pressure; otherwise the system pressure will be over high.

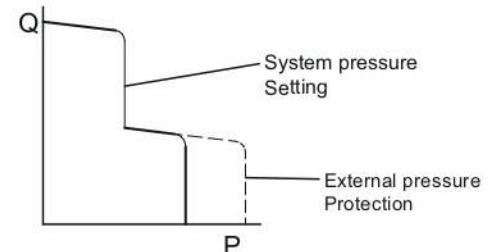
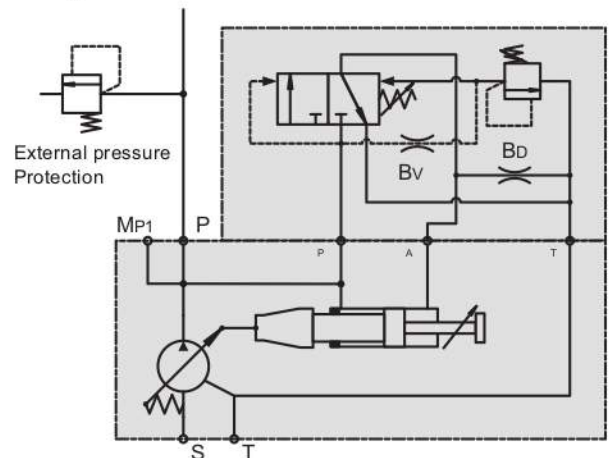

GM Remote pressure compensator with NG6 interface

A

12

PV Axial piston pump

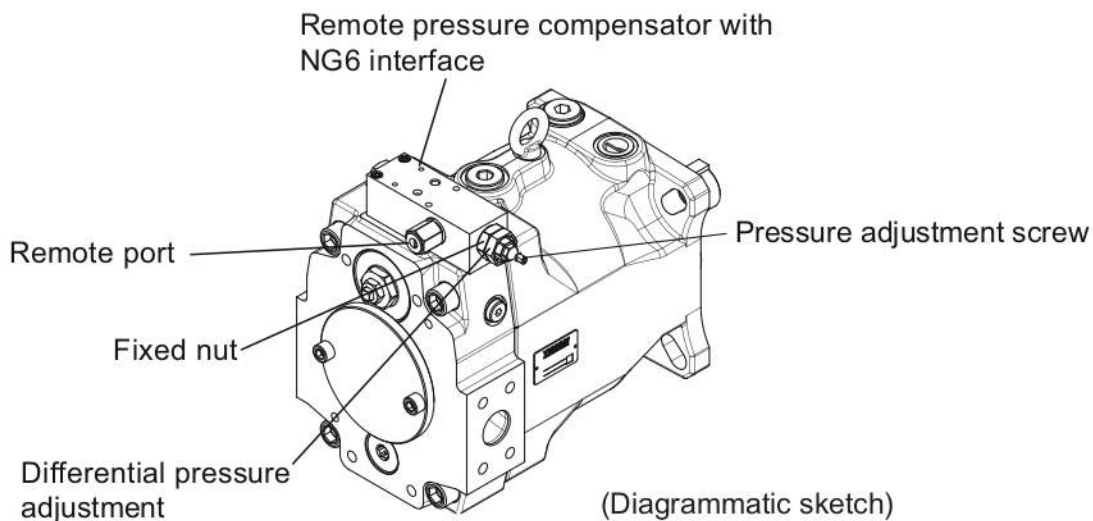

GM Remote pressure compensator with NG6 interface

Version GM of the remote pressure compensator provides on its top side an interface NG6, DIN24340 (CETOP 03 at RP35H, NFPA D03).

This interface allows a direct mounting of a pilot valve. Beside manual or electrohydraulic operated valves, it is also possible to mount complete multiple pressure circuits directly on the compensator body.

YEOSHE offers a variety of these compensator accessories ready to install.

All remote pressure compensator have a factory setting of 15 bar differential pressure.

With this setting, the controlled pressure at the pump outlet is higher than the pressure controlled by the pilot valve.

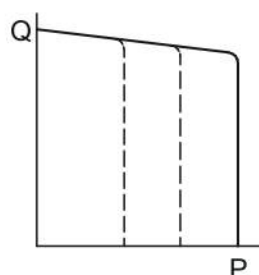
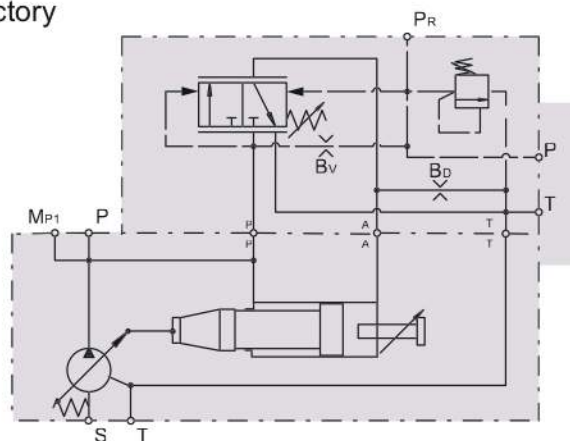

GA Remote pressure compensator + Relief valve **YEOSHE**

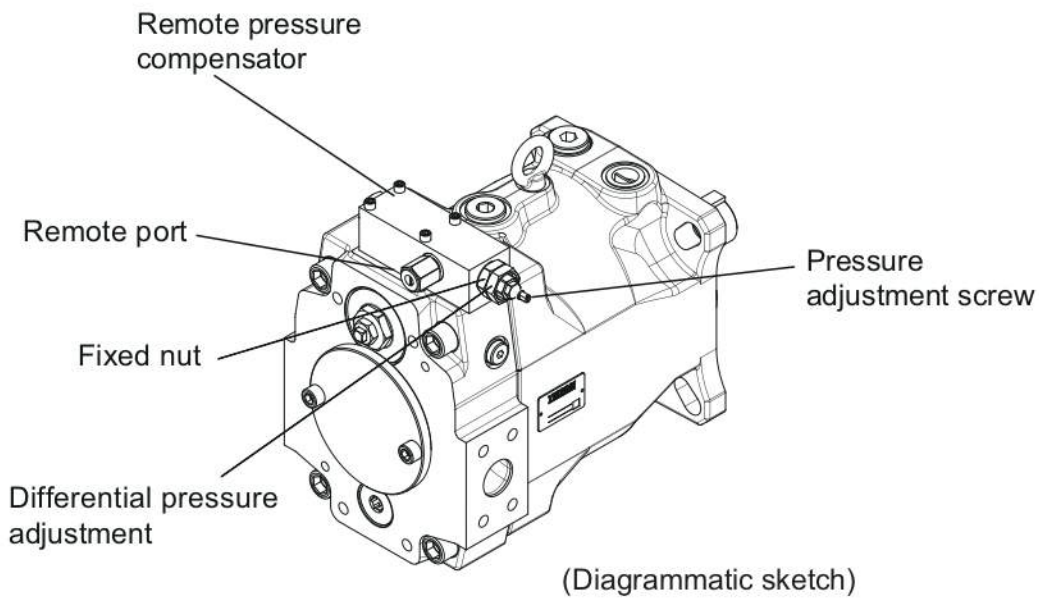

GA Remote pressure compensator + Relief valve

The pressure is set directly at the compensator spring, and the setting of remote pressure compensator can be achieved by any suitable pilot pressure valve connected to pilot port PP.

The pilot valve can be installed remote from the pump in some distance.

That allows pressure setting, e.g. from the control panel of the machine. The pilot flow supply is internal through the valve spool, and the pilot flow is 1~1.5 L/min.

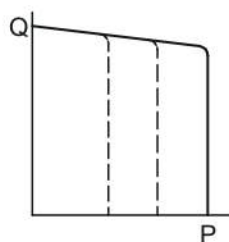
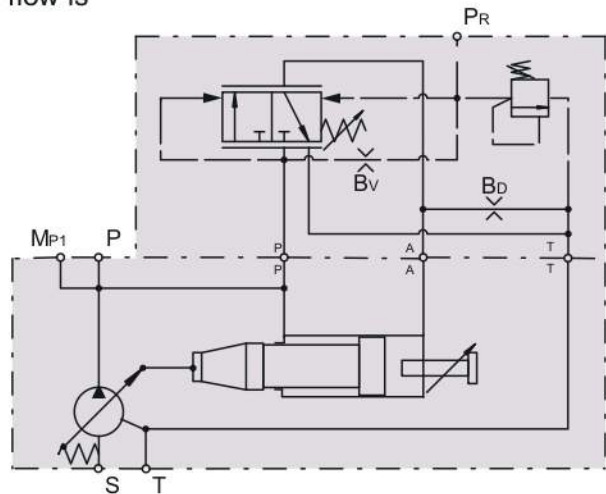



GJ Remote pressure compensator + Proportional pressure valve

A

14

PV Axial piston pump

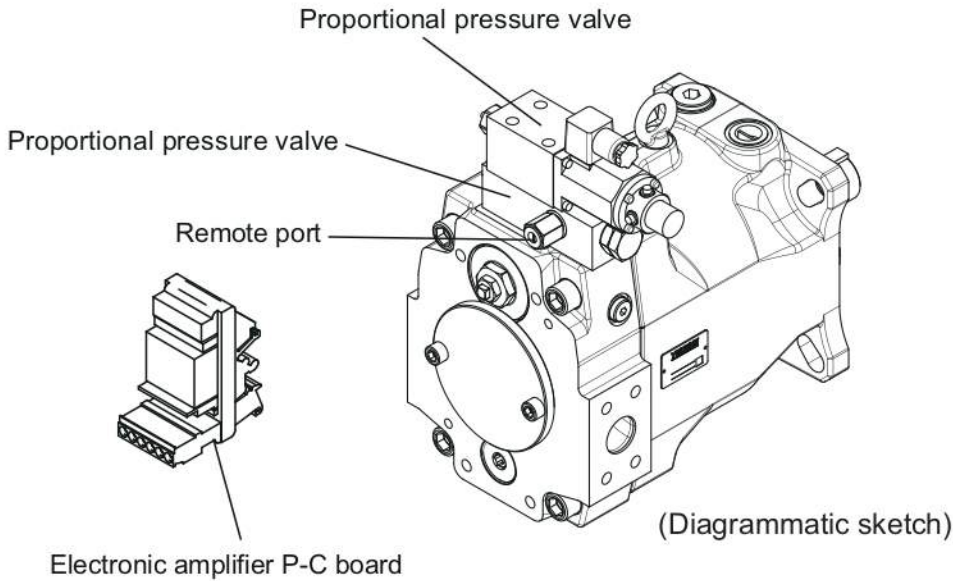

GJ Remote pressure compensator + Proportional pressure valve

Fulfill the actual displacement and maintain the preset system pressure.

By adding YEOSHE proportional pressure valve, electrical proportional pressure control is available.

- ※ Proportional pressure max.250 bar.
If needing any other pressure range, please contact YEOSHE.

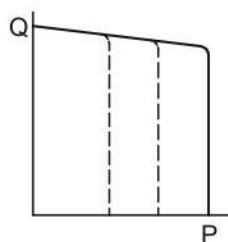
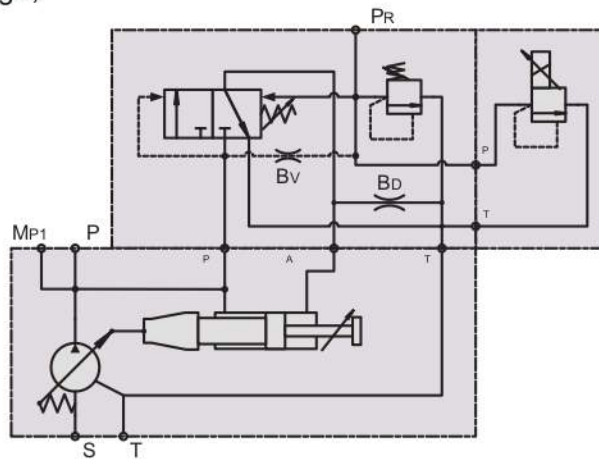

GR Remote pressure compensator + Electrical unloading

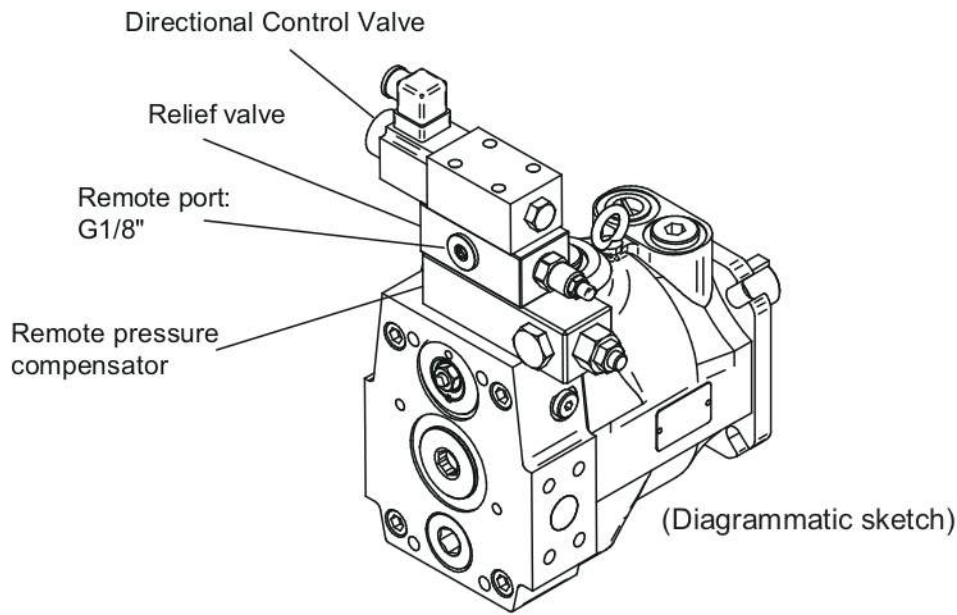

GR Remote pressure compensator + Electrical unloading

By adding a relief valve and a directional control valve on the compensator makes the pump have both function. GR control is for long unloading situation. When the system stops, oil temperature and noise maintain low level while being through the unloading.

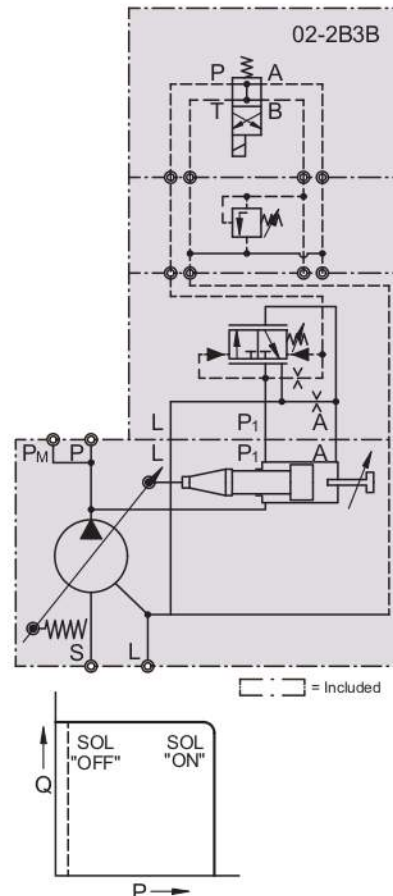



GB Remote pressure compensator + 2-stage pressure control

A

16

PV Axial piston pump

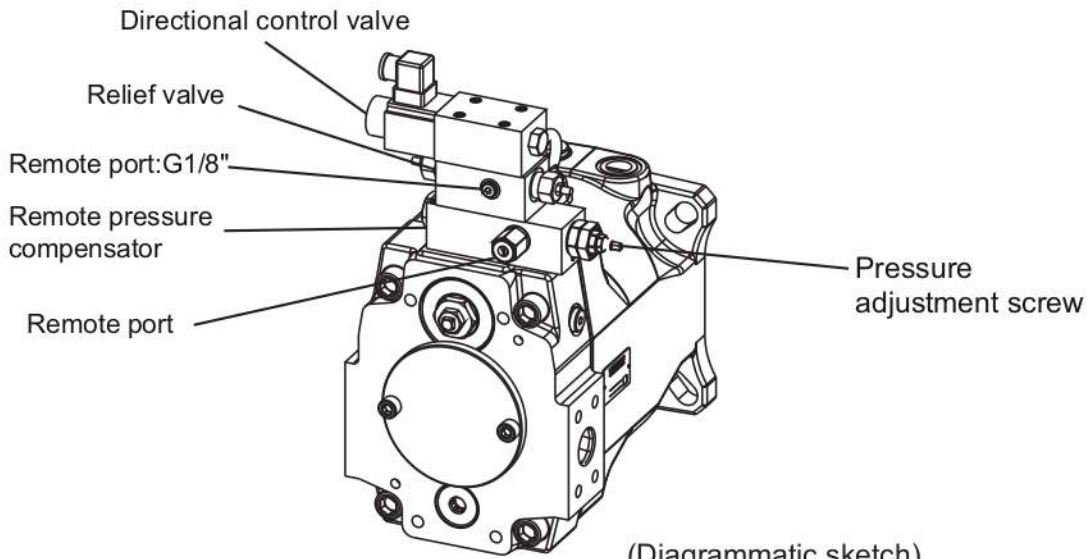

GB Remote pressure compensator + 2-stage pressure control

By adding a relief valve and directional control valve on the compensator makes it adjust two different stage limited pressure.

GB control is for two-stage working pressure under the constant cylinder speed.

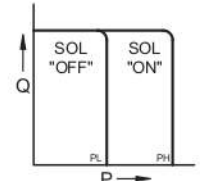
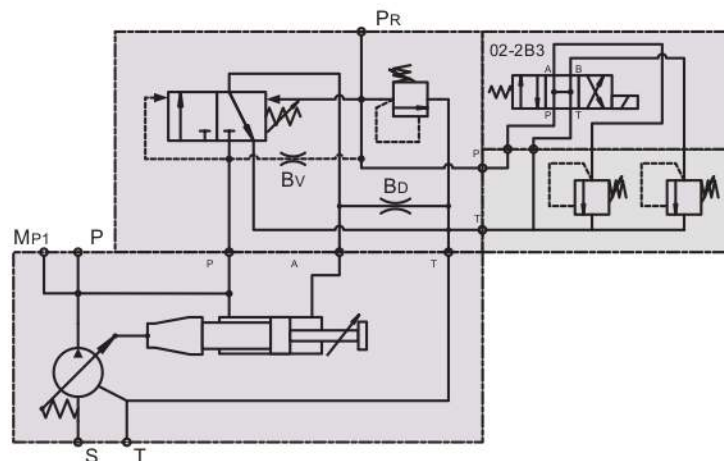

Either PL or PH valve can be high pressure side.

GC Remote pressure compensator + Electrical unloading + 2-stage pressure control

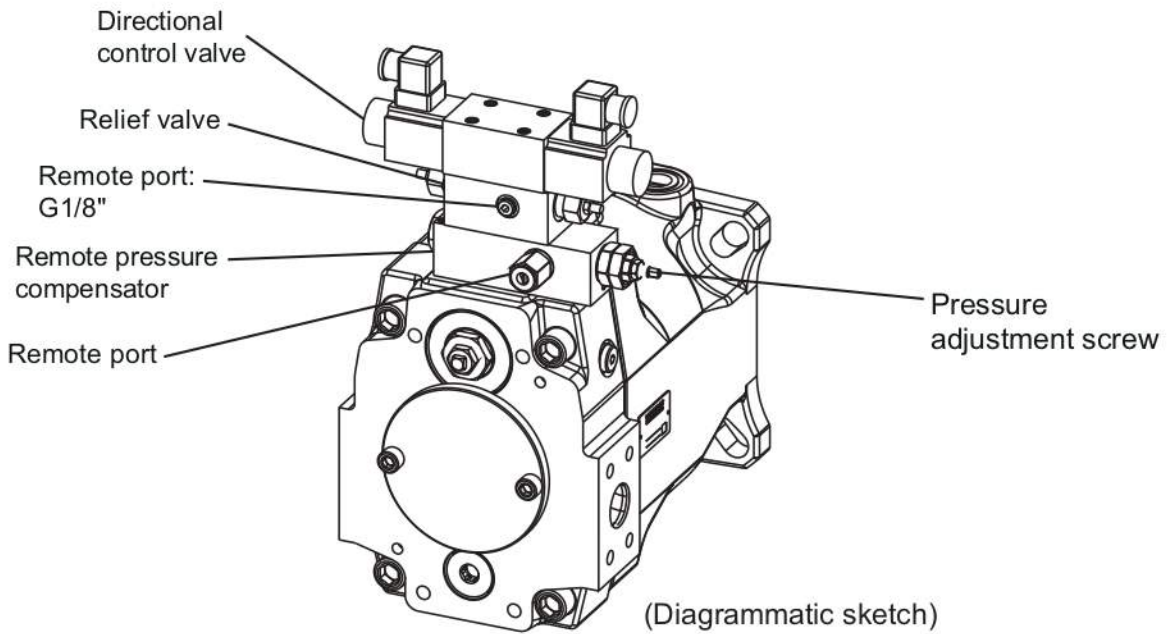

GC Remote pressure compensator + Electrical unloading + 2-stage pressure control

Control two different-stage limited pressure by adding directional control valve, and unloading function. When the system stops, oil temperature and noise maintain low level by unloading function. Usable for stable cylinder speed, two-stage pressure, and long unloading situation.

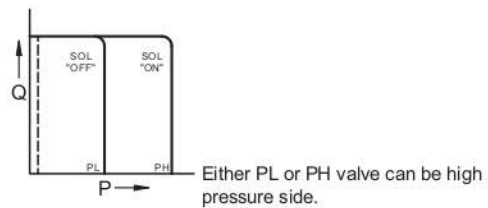
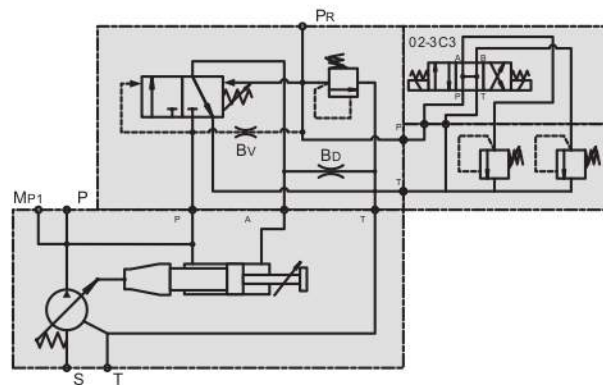



HM Load-sensing compensator with NG6 interface

A

18

PV Axial piston pump

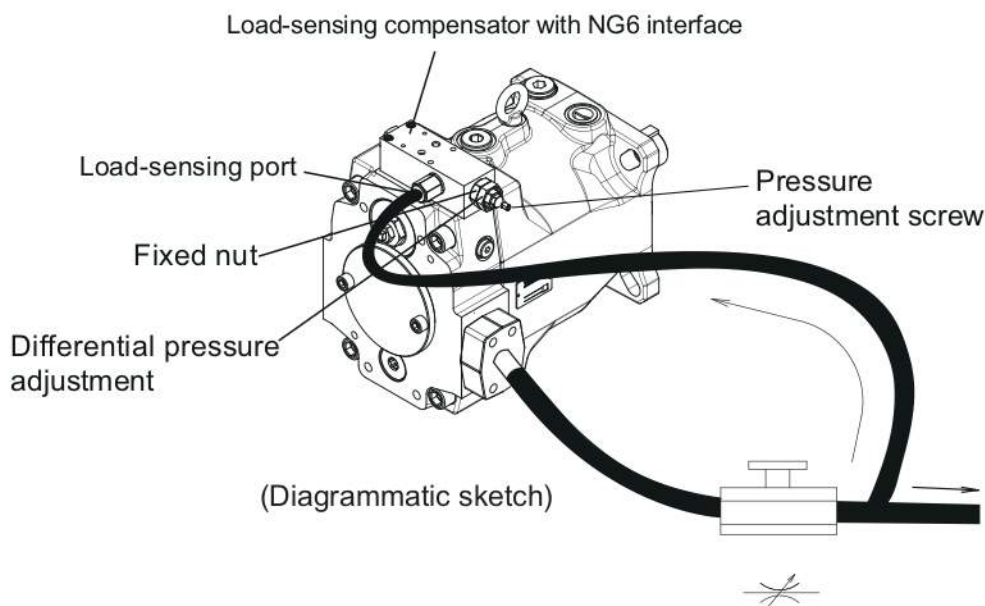

HM Load-sensing compensator with NG6 interface

Version HM of remote pressure compensator provides an interface NG6 on its top side.

The load-sensing compensator has an external pilot pressure supply.

Factory setting for the differential pressure is 10 bar.

The input signal to the compensator is the differential pressure at the main stream resistor.

A load-sensing compensator represents mainly a flow control for the pump output flow, because the compensator keeps the pressure drop at the main stream resistor constant.

A variable input speed or a varying load (-pressure) has consequently no influence on the output flow of the pump and the speed of the actuator.

By adding YEOSHE proportional pressure valve, electrical proportional pressure control is available.

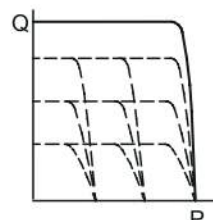
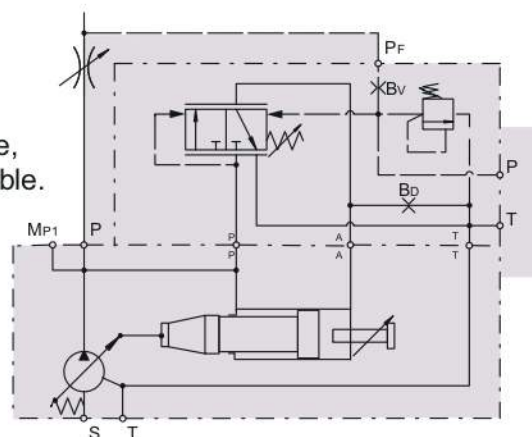

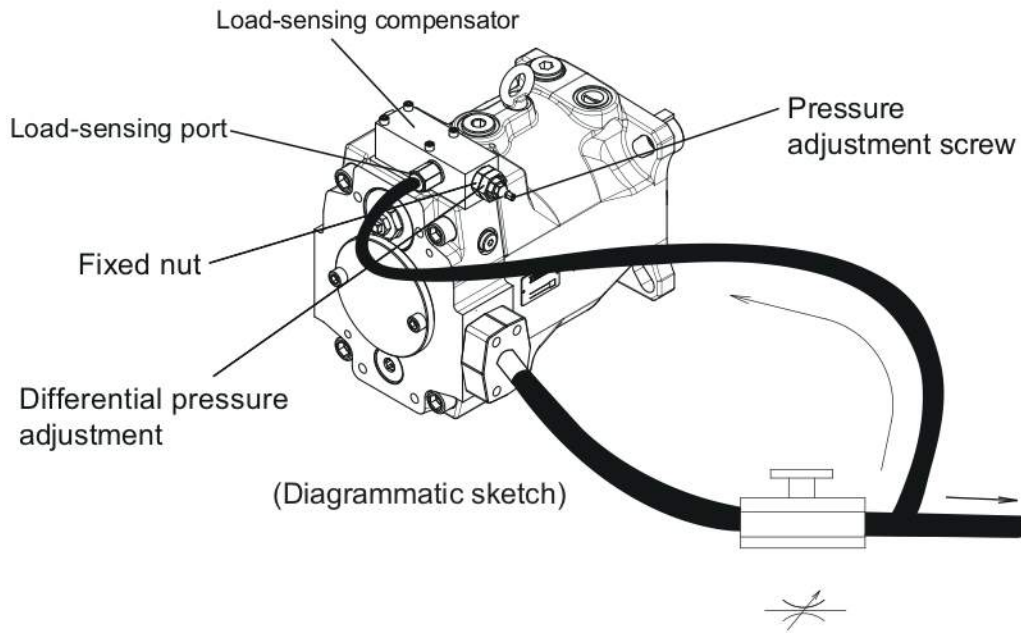

HA Load-sensing compensator + Relief valve

The load-sensing compensator has an external pilot pressure supply.

Factory setting for the differential pressure is 10bar.

The input signal to the compensator is the differential pressure at the main stream resistor.

A load-sensing compensator represents mainly a flow control for the pump output flow, because the compensator keeps the pressure drop at the main stream resistor constant.

A variable input speed or a varying load(-pressure) has consequent no influence on the output flow of the pump and the speed of the actuator.

Relief valve has adjustment function.

The pilot valve can be installed remote from the pump in some distance.

That allows pressure setting, e.g. from the control panel of the machine.

The pilot flow supply is internal through the valve spool, and the pilot flow is 1-1.5 L/min.

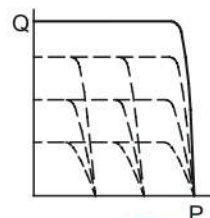
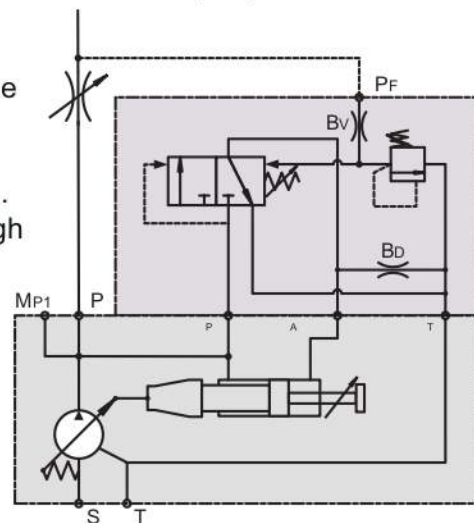

HJ Load-sensing compensator + Proportional pressure valve



A

20

PV Axial piston pump

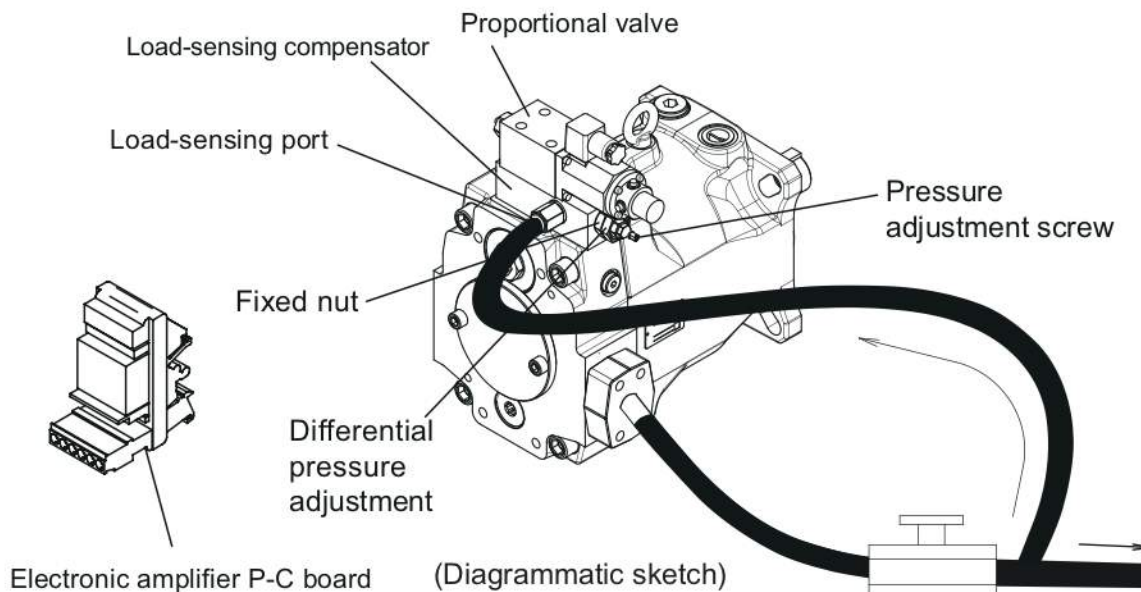

HJ Load-sensing compensator + Proportional pressure valve

The load-sensing compensator has an external pilot pressure supply.

Factory setting for the differential pressure is 10bar.

The input signal to the compensator is the differential pressure at the main stream resistor.

A load-sensing compensator represents mainly a flow control for the pump output flow and the speed of the actuator.

Proportional pressure valve is for electrical proportional pressure control.

- ※ Proportional pressure max.250 bar.
If needing any other pressure range, please contact YEOSHE.

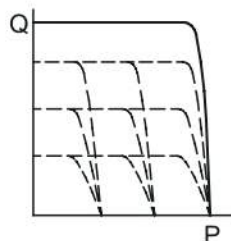
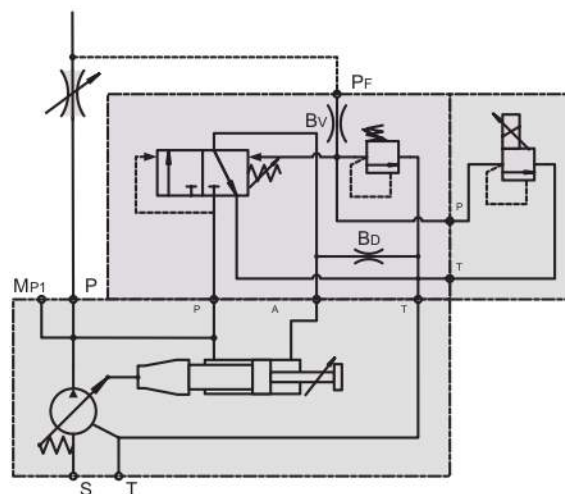

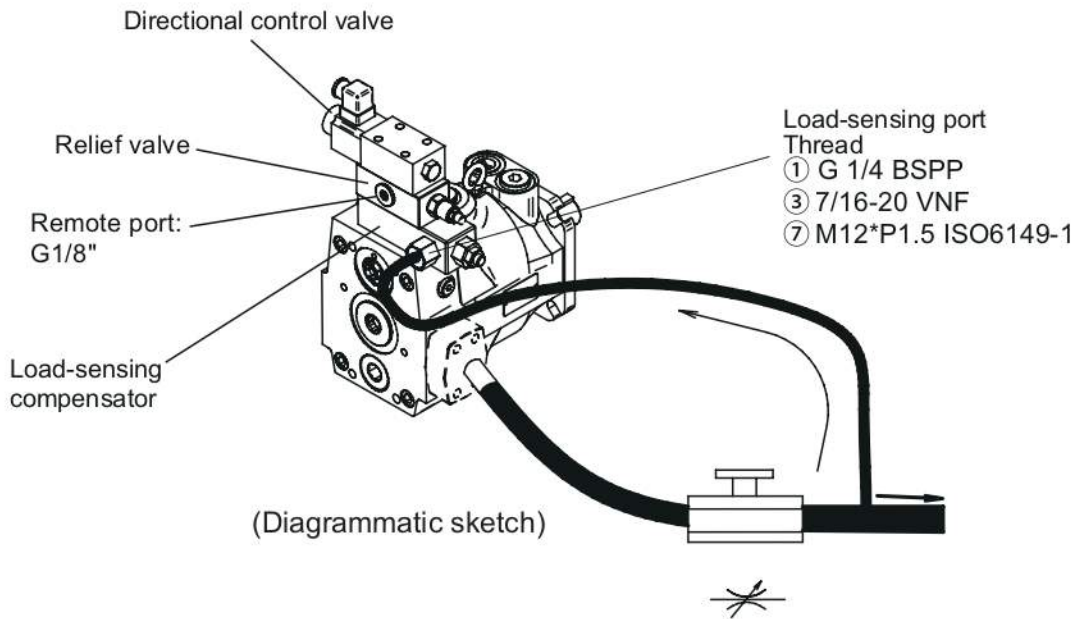

HR Load-sensing compensator + Electrical unloading

The load-sensing compensator has all external pilot pressure supply.

Factory setting for the differential pressure is 10bar.

The input signal to the compensator is the differential pressure at the main stream resistor.

A load-sensing compensator represents mainly a flow control for the pump output flow, because the compensator keeps the pressure drop at the main stream resistor constant.

A variable input speed or a varying (load -pressure) has consequently on the output flow of the pump and speed of the actuator.

By adding a pilot orifice ($\Phi 0.8\text{mm}$) and a pressure pilot valve pressure compensation can be added to the flow control function. See the circuit diagram left.

By adding a relief valve and a directional control valve on the compensator makes the pump have both function.

HR control is for long unloading situation.

When the system stops, oil temperature and noise maintain low level while being through the unloading.

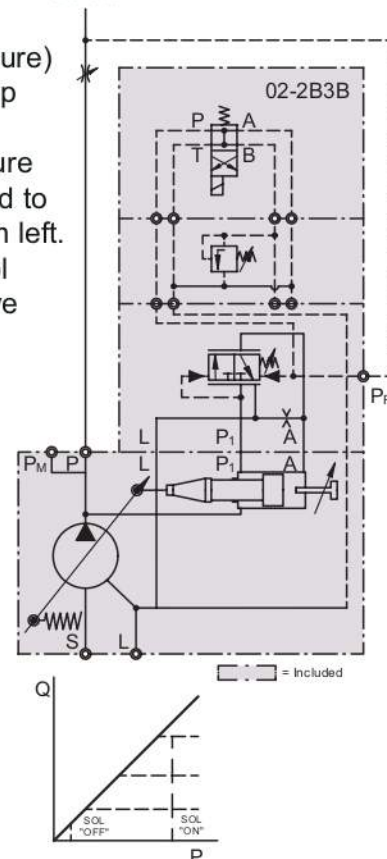



HB Load-sensing compensator + 2-stage pressure control

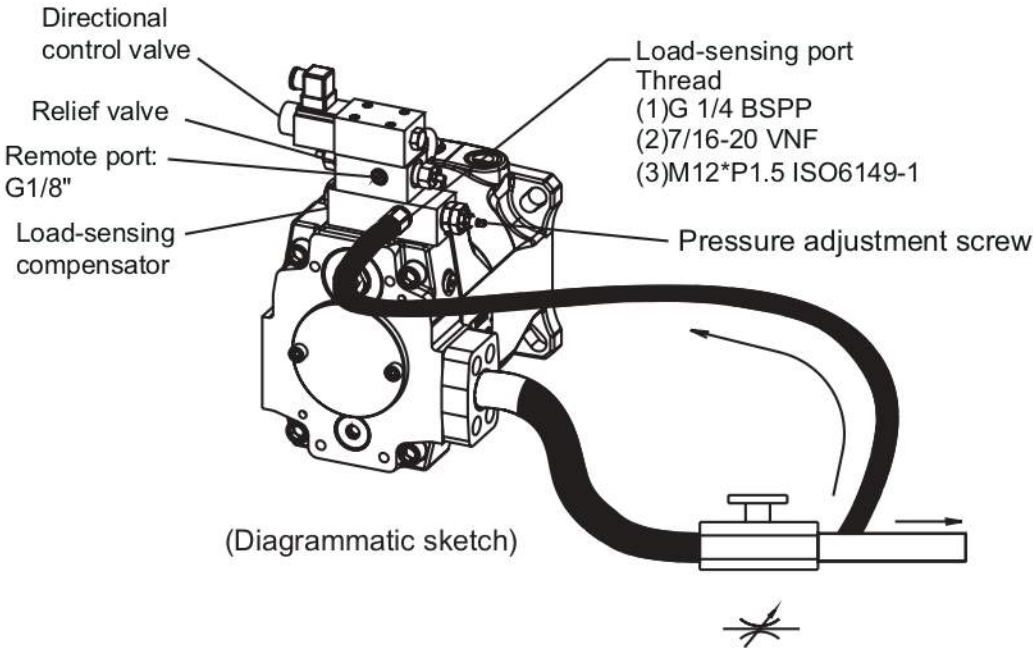

HB Load-sensing compensator + 2-stage pressure control

The load-sensing compensator has an external pilot pressure supply.

Factory setting for the differential pressure is 10bar.

The input signal to the compensator is the differential pressure at the main stream resistor.

A load-sensing compensator represents mainly a flow control for the pump output flow, because the compensator keeps the pressure drop at the main stream resistor constant.

A variable input speed or a varying (load -pressure) has consequently on the output flow of the pump and speed of the actuator.

By adding a pilot orifice ($\Phi 0.8\text{mm}$) and a pressure pilot valve pressure compensation can be added to the flow control function.

See the circuit diagram left.

By adding a relief valve and directional control valve on the compensator makes it adjust two different stage limited pressure.

HB control is for two-stage working pressure under the constant cylinder.

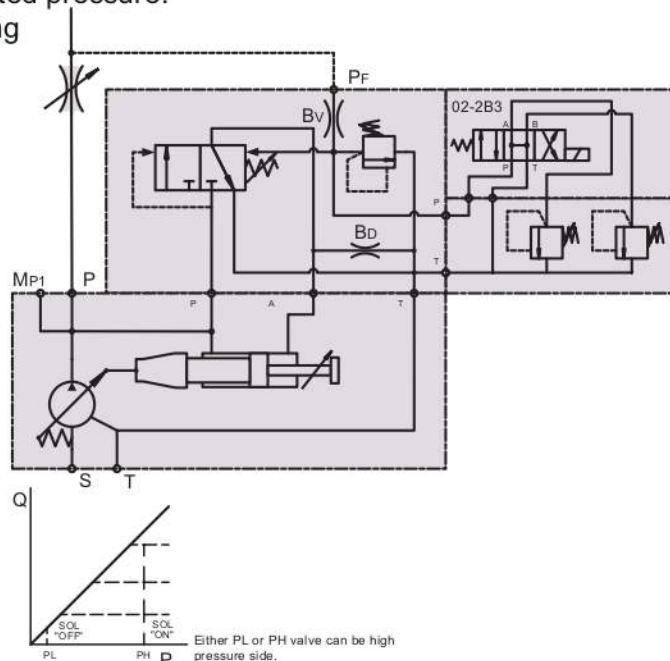

HC Load-sensing compensator + Electrical unloading + 2-stage pressure control

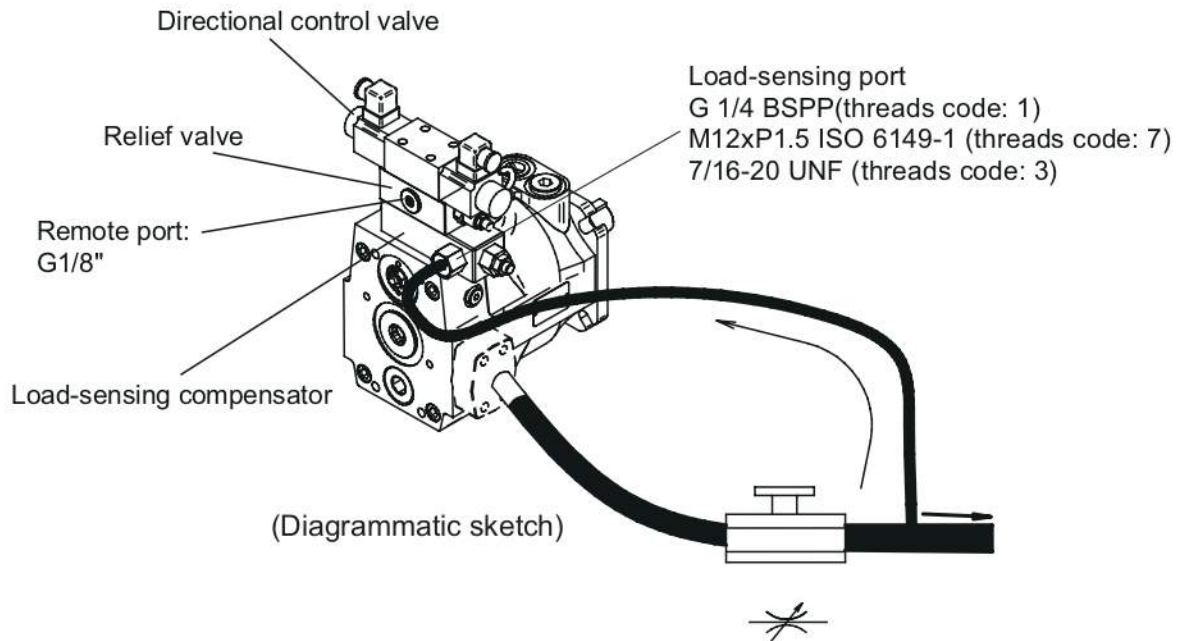

HC Load-sensing compensator + Electrical unloading + 2-stage pressure control

The load-sensing compensator has an external pilot pressure supply. Factory setting for the differential pressure is 10bar.

The input signal to the compensator is the differential pressure at the main stream resistor.

A load-sensing compensator represents mainly a flow control for the pump output flow, because the compensator keeps the pressure drop at the main stream resistor constant.

A variable input speed or a varying (load -pressure) has consequently on the output flow of the pump and speed of the actuator.

By adding a pilot orifice ($\Phi 0.8\text{mm}$) and a pressure pilot valve pressure compensation can be added to the flow control function.

See the circuit diagram left.

By adding a relief valve and a directional control valve on the compensator makes the pump have both function.

HC control is for long unloading situation.

When the system stops, oil temperature and noise maintain low level while being through the unloading.

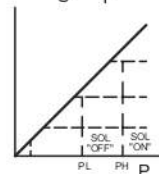
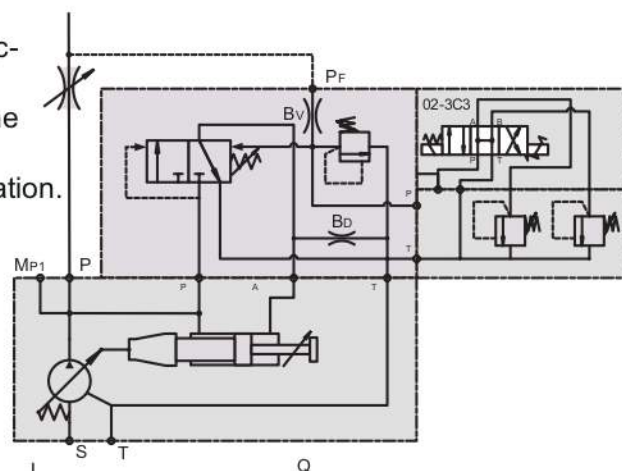

Either PL or PH valve can be high pressure side.

HQ Load-sensing compensator + Proportional flow valve + Relief valve



Load-sensing compensator

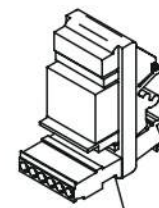
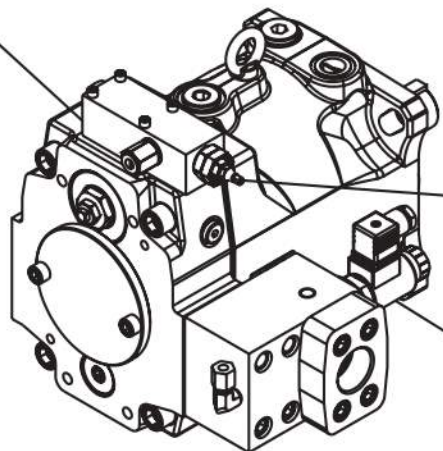

Electronic amplifier P-C board compensator

(Diagrammatic sketch)

HQ Load-sensing compensator + Proportional flow valve + Relief valve

The load-sensing compensator has an external pilot pressure supply.
 Factory setting for the differential pressure is 10bar.
 The input signal to the compensator is the differential pressure at the main stream resistor.
 A load-sensing compensator represents mainly a flow control for the pump output flow, because the compensator keeps the pressure drop at the main stream resistor constant.
 By adding YEOSHE proportional flow valve, electrical proportional flow control is available.

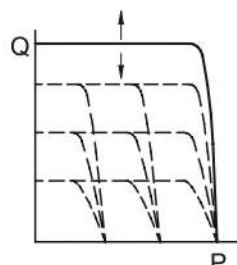
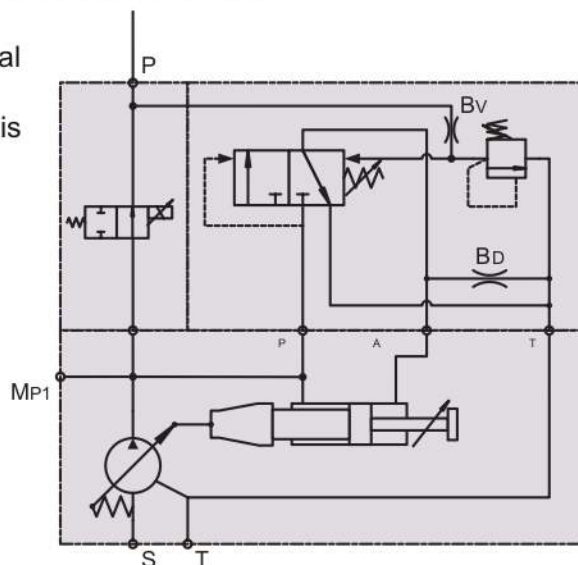

HK Load-sensing compensator + Proportional pressure valve + Proportional flow valve **YEOSHE**

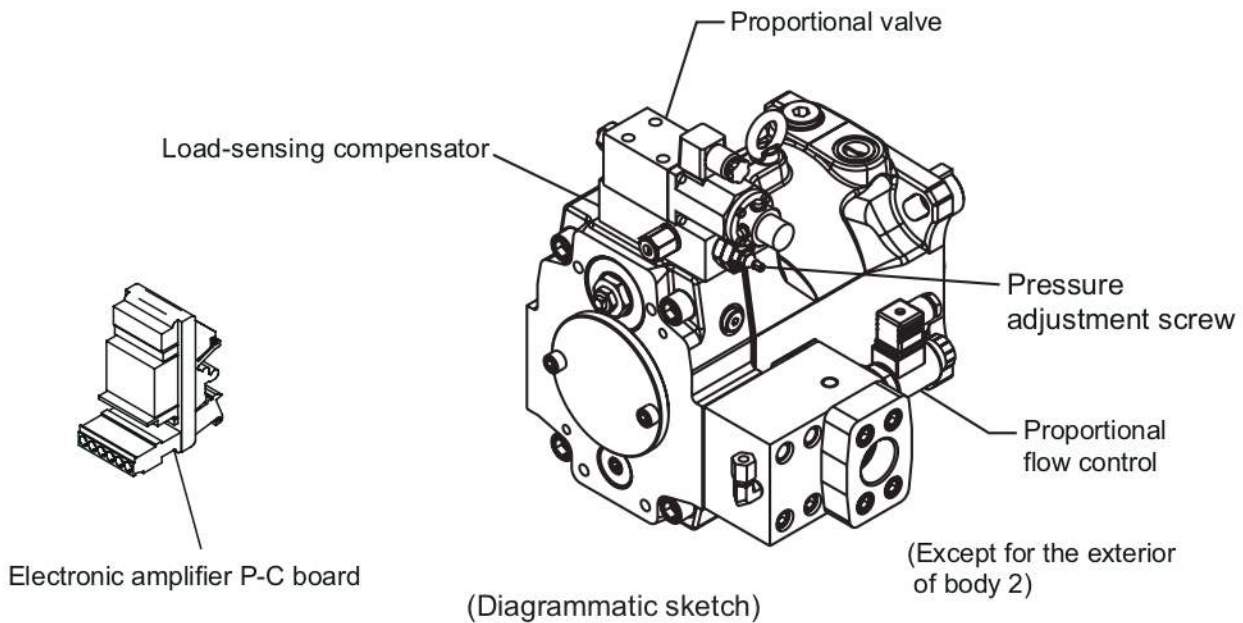

HK Load-sensing compensator + Proportional pressure valve + Proportional flow valve

HK is for saving energy.

It offers the smallest pressure and flow according to the different requirement.

The displacement is nearly zero when the system stands by, and the motor output is also nearly zero.

When the system reaches setting pressure, the pump displacement will reduce by itself.

It only needs to add the system required flow, and the pressure remains the same which control the oil temperature.

Compared with vane pump, gear pump + PQ valve can save 30%-50% energy.

The load-sensing compensator + proportional flow valve has all external pilot pressure supply.

Factory setting for the differential pressure is 10 bar.

The input signal to the compensator is the differential pressure at the main stream resistor.

A load-sensing compensator represents mainly a flow control for the pump output flow of the pump and the speed of the actuator.

Proportional pressure valve is for electrical proportional pressure control.

- ※ Proportional pressure max.250 bar.
If needing any other pressure range,
please contact YEOSHE.

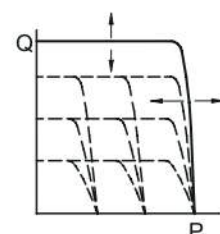
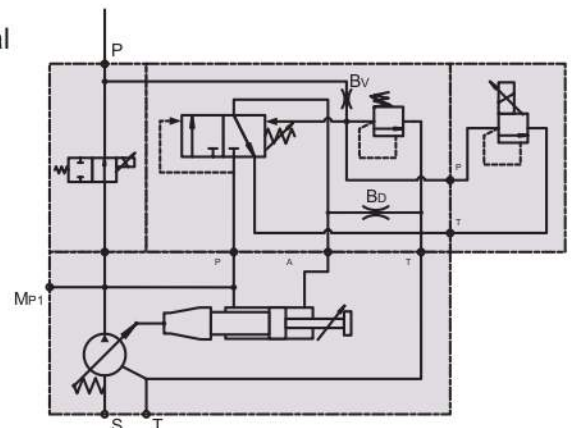



PM Horse power compensator with NG6 interface

A

26

PV Axial piston pump

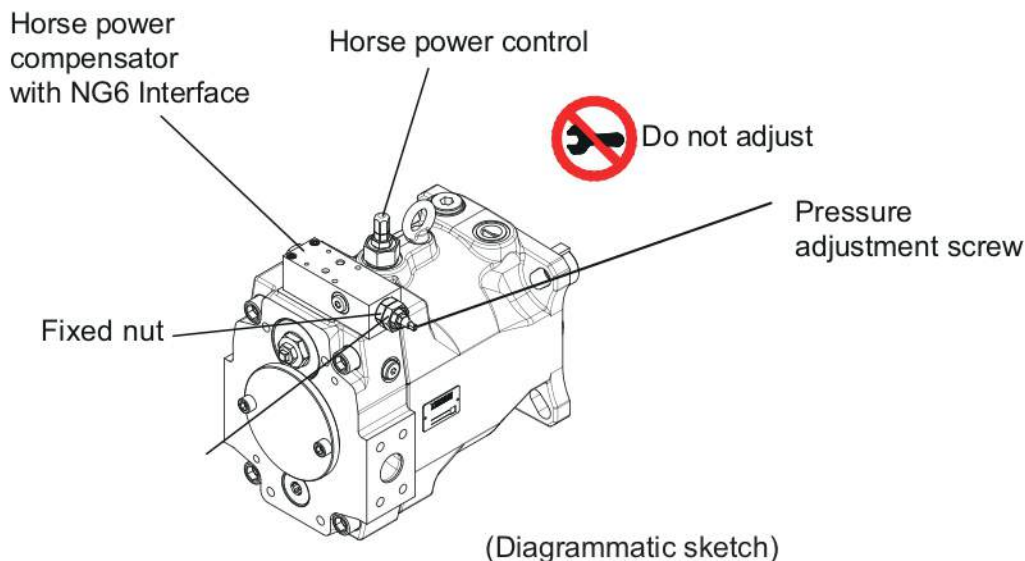

PM Horse power compensator with NG6 interface

The hydraulic-mechanical horse power compensator consists of a modified remote pressure compensator or of a modified load-sensing compensator and a pilot valve.

This pilot valve is integrated into the pump and is adjusted by a cam sleeve.

The cam sleeve has a contour that is designed and machined for the individual displacement and the nominal horse power setting.

At a large displacement the opening pressure (given by the cam sleeve diameter) is lower than at small displacements.

This makes the pump compensate along a constant horse power (torque) curve.

Horse power is optional when order.

Working pressure can be adjusted by adding YEOSHE pressure leading valve.

Adding the proportional pressure valve achieves the electrical proportional pressure control.

※ Horse power setting, please following type code.

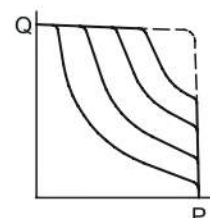
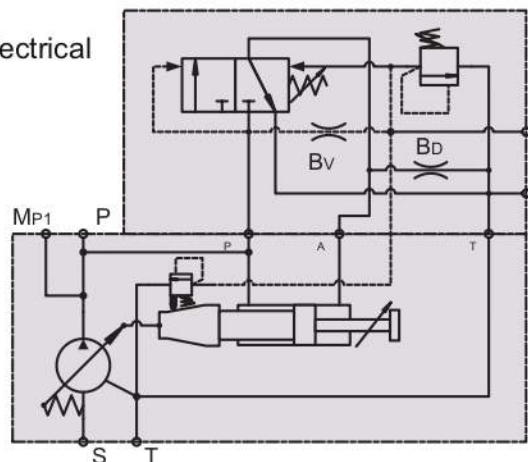

PA Horse power compensator + Relief valve

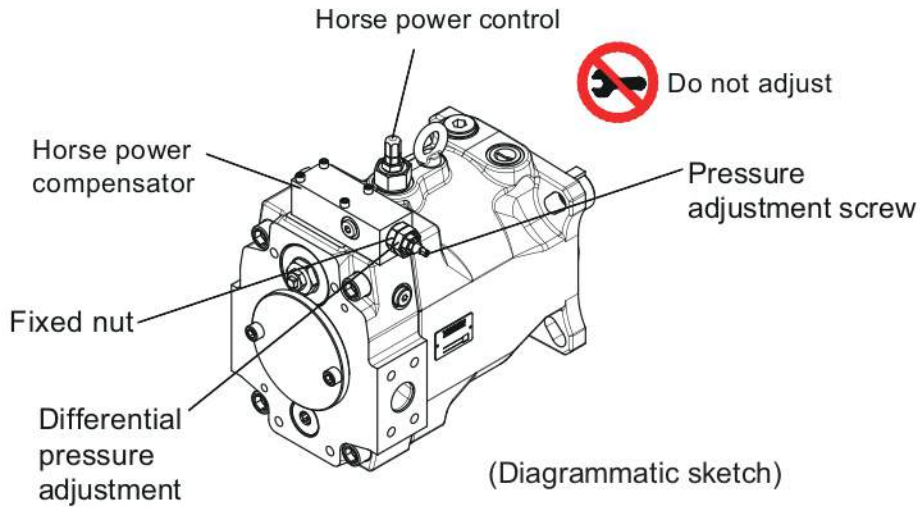

PA Horse power compensator + Relief valve

The hydraulic-mechanical horse power compensator consists of a modified remote pressure compensator or of a modified load-sensing compensator and a pilot valve.

This pilot valve is integrated into the pump and is adjusted by a cam sleeve.

The cam sleeve has a contour that is designed and machined for the individual displacement and the nominal horse power setting.

At a large displacement the opening pressure (given by the cam sleeve diameter) is lower than at small displacements.

This makes the pump compensate along a constant horse power (torque) curve.

Horse power is optional when order.

Working pressure can be adjusted by adding YEOSHE pressure leading valve.

Adding the proportional pressure valve achieves the electrical proportional pressure control.

The pilot valve can be installed remote from the pump in some distance.

That allows pressure setting e.g. from the control panel of the machine.

The pilot flow supply is internal through the valve spool and the pilot flow is 1-1.5 L/min.

※ Horse power setting, please following type code.

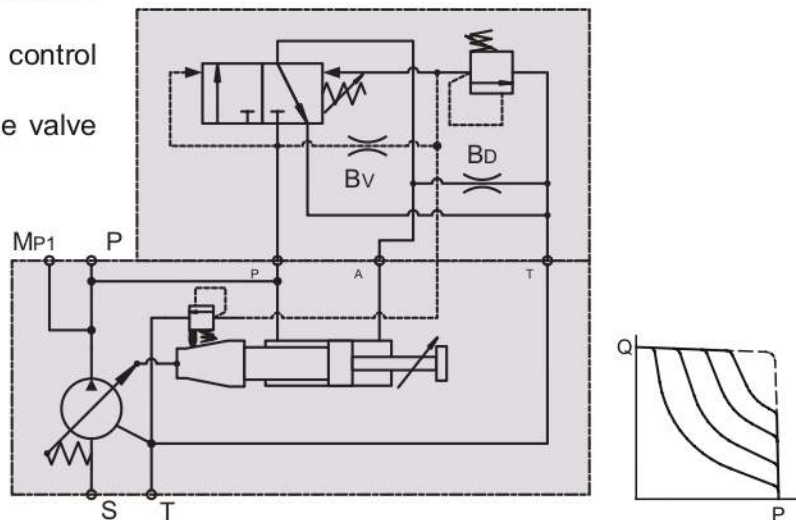

PJ Horse power compensator + Proportional pressure valve



A

28

PV Axial piston pump

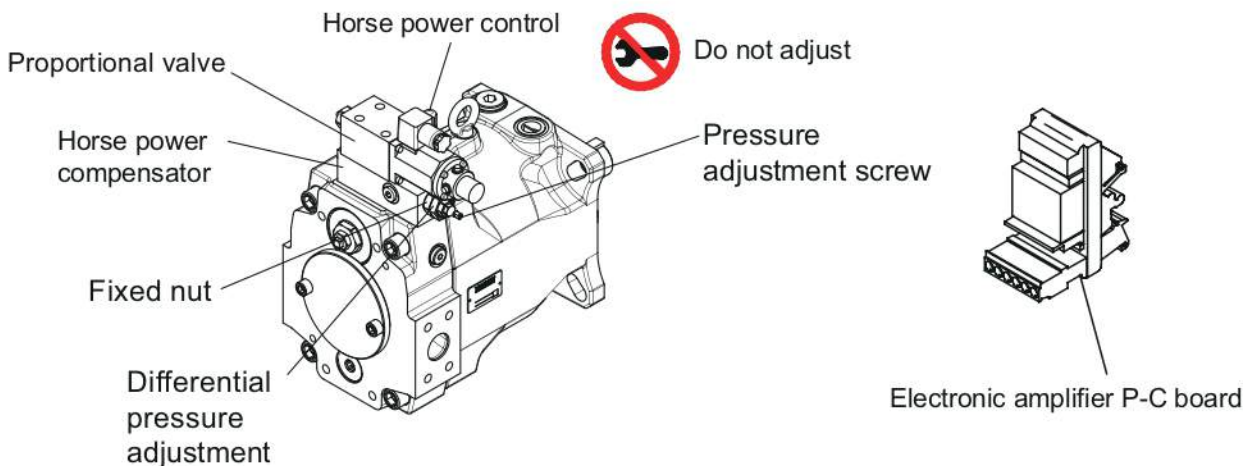

(Diagrammatic sketch)

PJ Horse power compensator + Proportional pressure valve

The hydraulic- mechanical horse power compensator consists of a modified remote pressure compensator or of a modified load-sensing compensator and a pilot valve. This pilot valve is integrated into the pump and is adjusted by a cam sleeve. The cam sleeve has a contour that is designed and machined for the individual displacement and the nominal horse power setting. At a large displacement the opening pressure (given by the cam sleeve diameter) is lower than at small displacements. This makes the pump compensate along a constant horse power (torque) curve. Pressure-adjusted function is optional by adding a leading proportional pressure valve.

※ Horse power setting, please following type code.

※ Proportional pressure max.250 bar.
If needing any other pressure range, please contact YEOSHE.

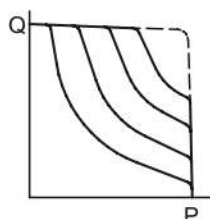
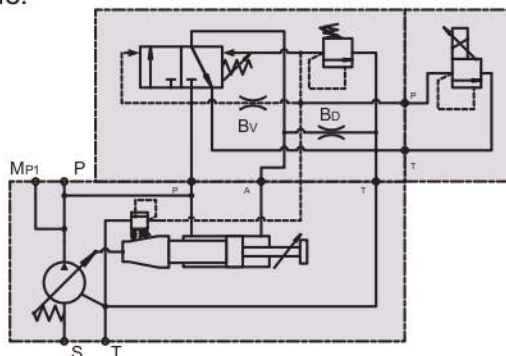

PR Horse power compensator + Electrical unloading

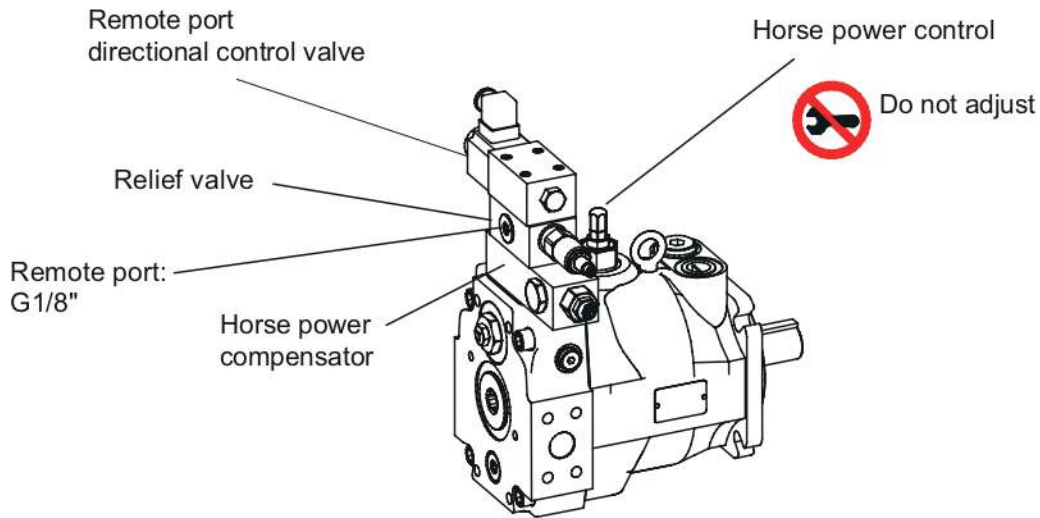

(Diagrammatic sketch)

PR Horse power compensator + Electrical unloading

The hydraulic-mechanical horse power compensator consists of a modified remote pressure compensator or of a modified load-sensing compensator and a pilot valve.

This pilot valve is integrated into the pump and is adjusted by a cam sleeve.

The cam sleeve has a contour that is designed and machined for the individual displacement and the nominal horse power setting.

At a large displacement the opening pressure (given by the cam sleeve diameter) is lower than at small displacements.

This makes the pump compensate along a constant horse power (torque) curve.

Electrical unloading function is optional by adding an electric directional control valve.

This control is suitable for long period of unloading.

Oil temperature and noise remain low level through out the electrical unloading function when the system stops working.

※ Horse power setting, please following type code.

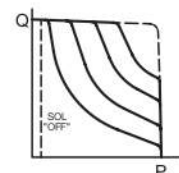
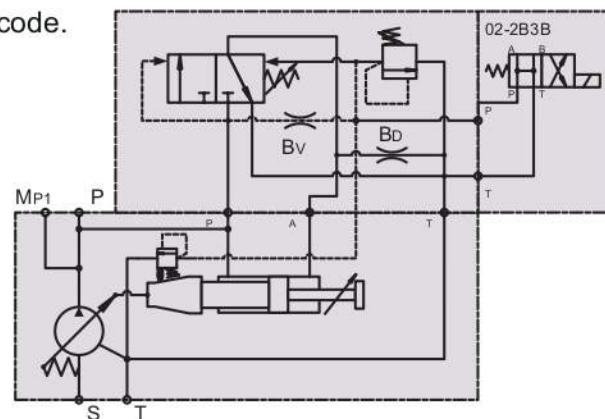

PC Horse power compensator + Electrical unloading +2-stage pressure control



A

30

PV Axial piston pump

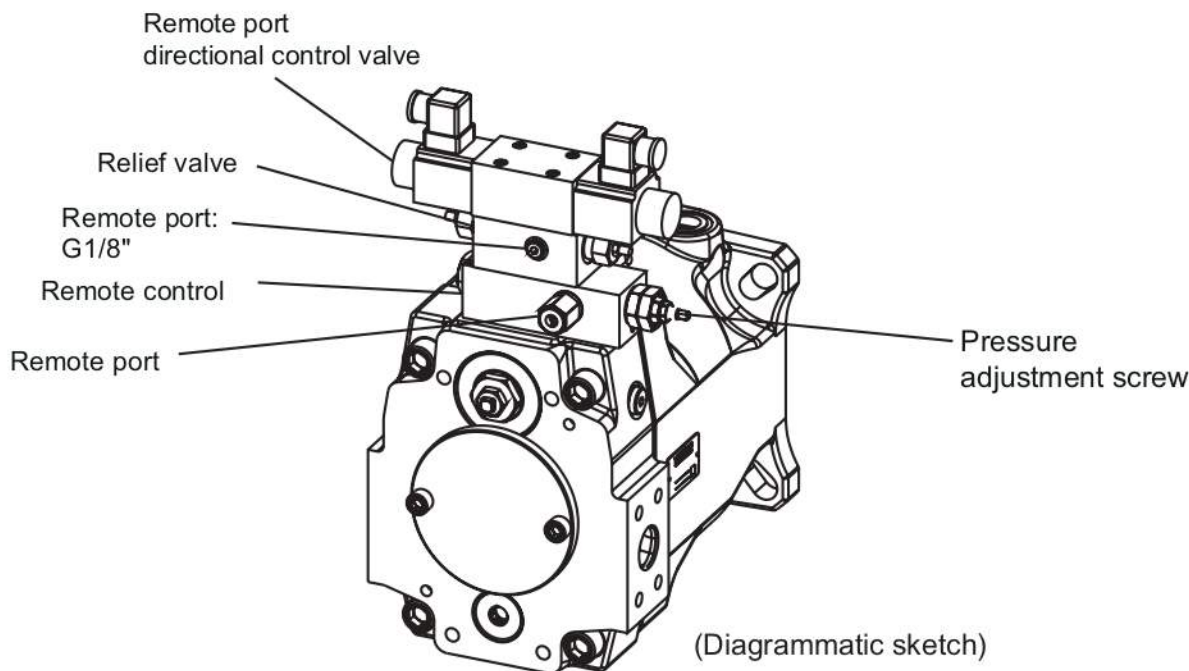

PC Horse power compensator + Electrical unloading+2-stage pressure control

The hydraulic-mechanical horse power compensator consists of a modified remote pressure compensator or of a modified load-sensing compensator and a pilot valve.

This pilot valve is integrated into the pump and is adjusted by a cam sleeve.

The cam sleeve has a contour that is designed and machined for the individual displacement and the nominal horse power setting.

At a large displacement the opening pressure (given by the cam sleeve diameter) is lower than at small displacements.

Control two different-stage limited pressure by adding directional control valve, and unloading function.

When the system stops, oil temperature and noise maintain low level by unloading function. Usable for stable cylinder speed, two-stage pressure, and long unloading situation.

※ Horse power setting, please following type code.

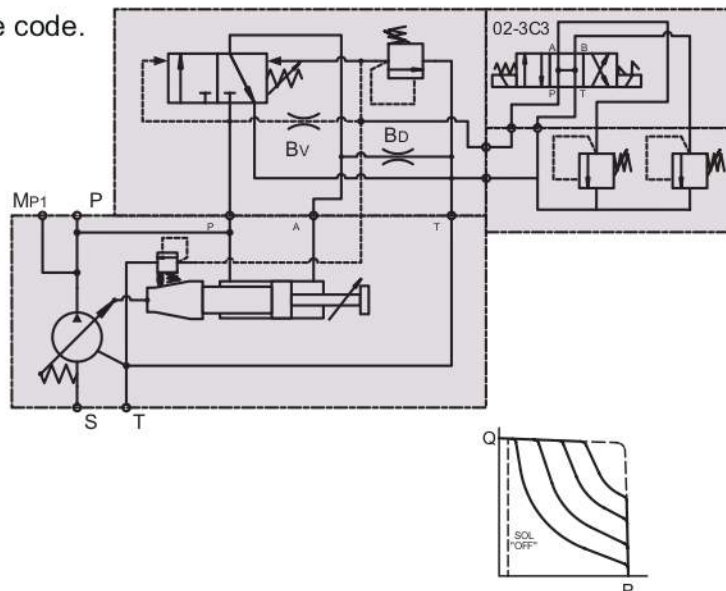

PH Horse power load-sensing compensator + Relief valve

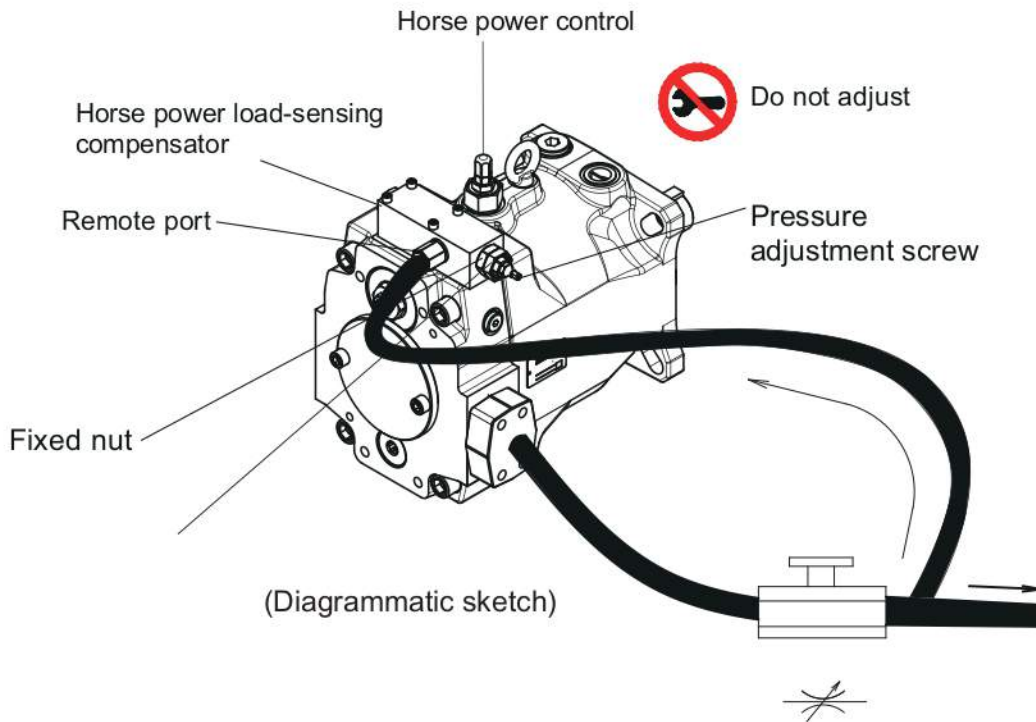

PH Horse power load-sensing compensator + Relief valve

The hydraulic-mechanical horse power compensator consists of a modified remote pressure compensator or of a modified load-sensing compensator and a pilot valve.

This pilot valve is integrated into the pump and is adjusted by a cam sleeve.

The cam sleeve has a contour that is designed and machined for the individual displacement and the nominal horse power setting.

At a large displacement the opening pressure (given by the cam sleeve diameter) is lower than at small displacements.

This makes the pump compensate along a constant horse power (torque) curve.

Horse power is optional when order.

Working pressure can be adjusted by adding a leading valve on the compensator, and pump flow can also be adjusted on the first pipe by adding an external feedback on the PF port as a control signal on the main stream.

The pilot valve can be installed remote from the pump in some distance.

That allows pressure setting, e.g. from the control panel of the machine.

The pilot flow supply is internal through the valve spool, and the pilot flow is 1~1.5 L/min.

※Horse power setting, please following type code.

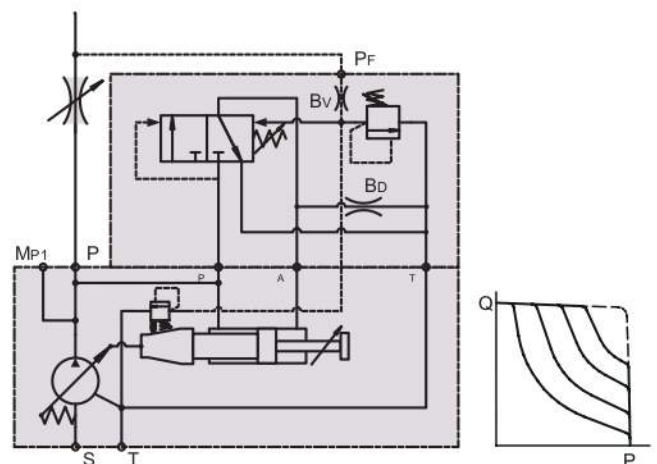



PQ Horse power load-sensing compensator + Proportional flow valve + Relief valve

A

32

PV Axial piston pump

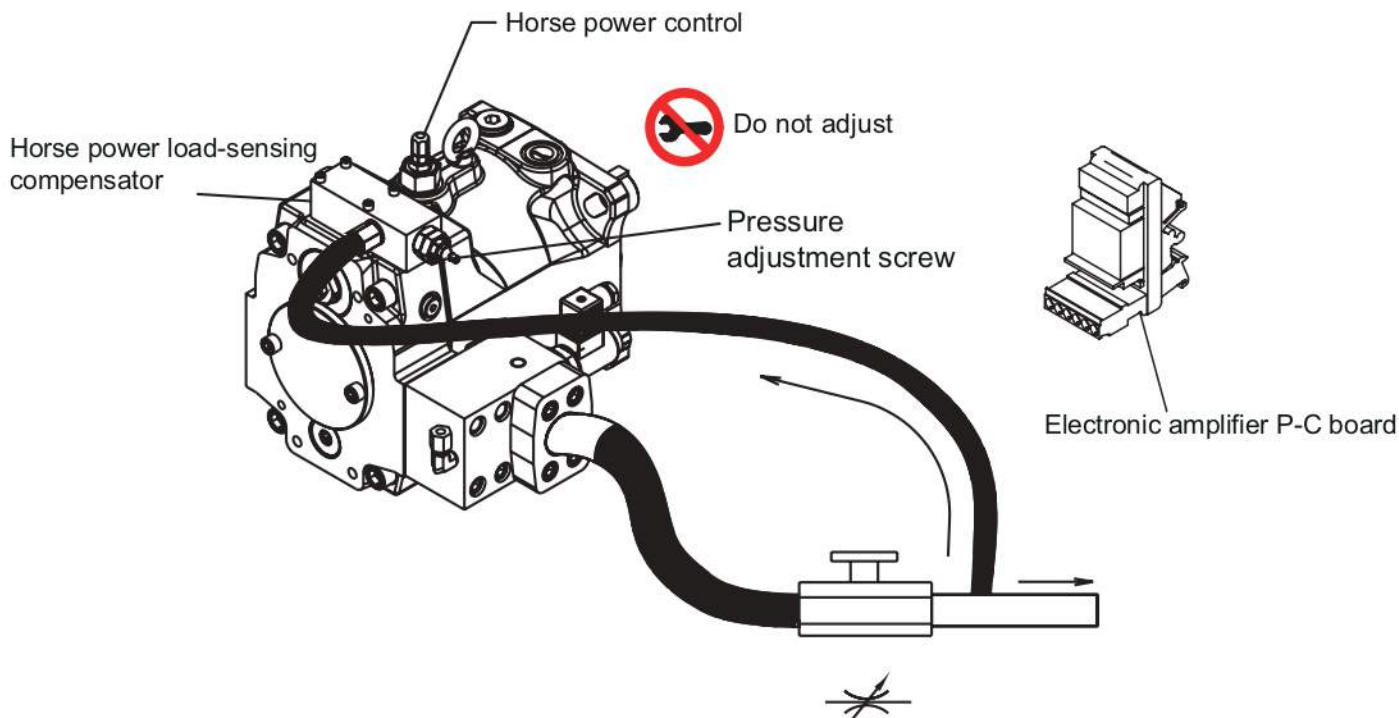

PQ Horse power load-sensing compensator + Proportional flow valve + Relief valve

The hydraulic-mechanical horse power compensator consists of a modified remote pressure compensator or of a modified load-sensing compensator and a pilot valve.

This pilot valve is integrated into the pump and is adjusted by a cam sleeve.

The cam sleeve has a contour that is designed and machined for the individual displacement and the nominal horse power setting.

At a large displacement the opening pressure (given by the cam sleeve diameter) is lower than at small displacements.

This makes the pump compensate along a constant horse power (torque) curve.

Pressure can be adjusted by adding a leading valve in the compensator, and pump flow can also be adjusted on the first pipe by adding an external feedback on the PF port as a control signal on the main stream.

Adding a proportional flow control valve on the P port achieves electrical proportional flow control.

※ Horse power setting, please following type code.

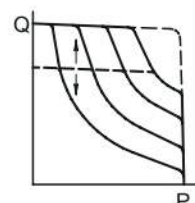
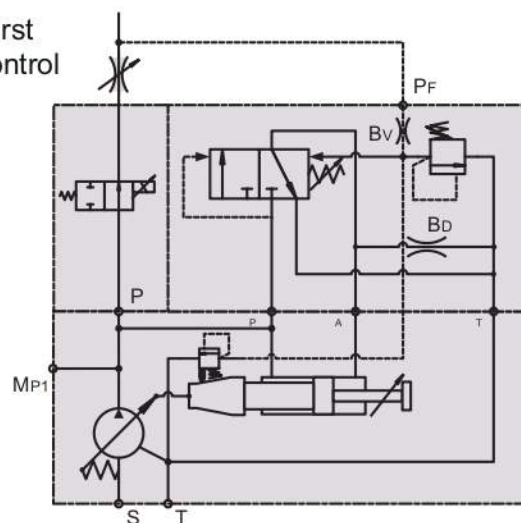

PS Horse power load-sensing compensator + Proportional pressure valve

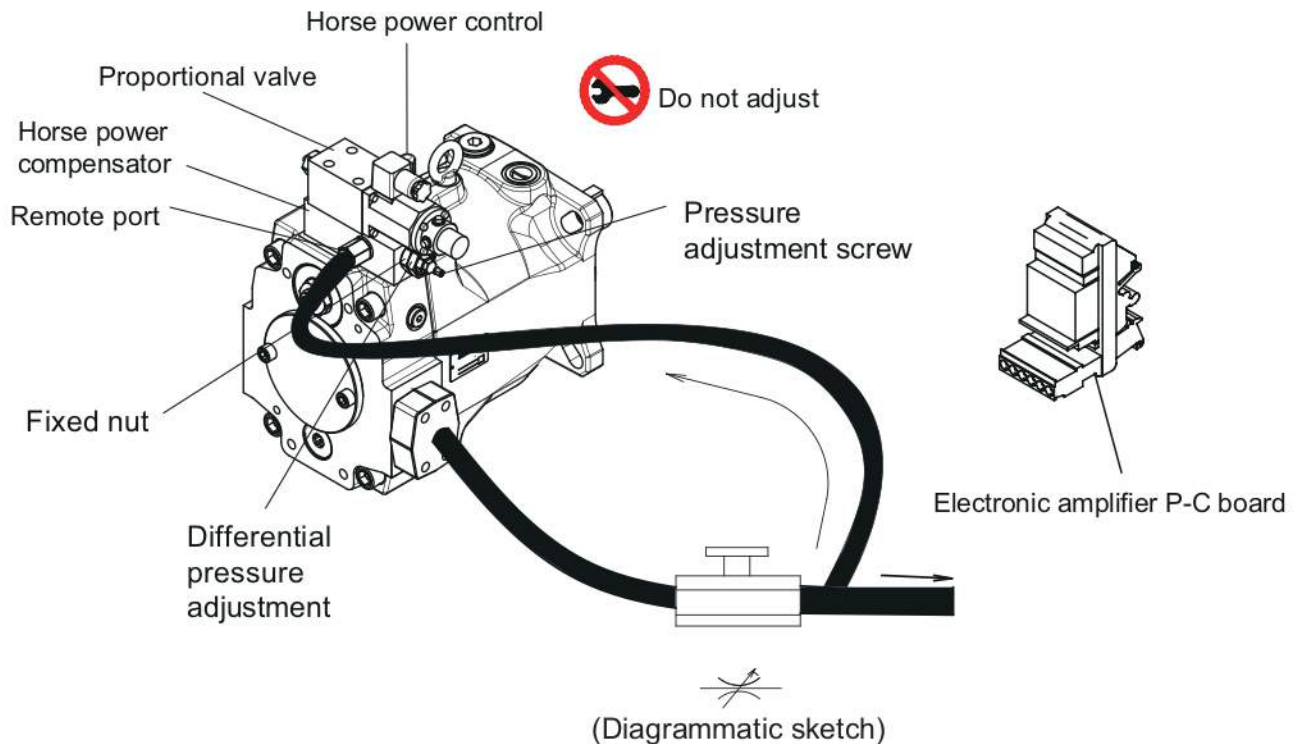

PS Horse power load-sensing compensator + Proportional pressure valve

The hydraulic-mechanical horse power compensator consists of a modified remote pressure compensator or of a modified load-sensing compensator and a pilot valve. This pilot valve is integrated into the pump and is adjusted by a cam sleeve. The cam sleeve has a contour that is designed and machined for the individual displacement and the nominal horse power setting. At a large displacement the opening pressure (given by the cam sleeve diameter) is lower than at small displacements. This makes the pump compensate along a constant horse power (torque) curve. Electrical pressure-adjusted function is optional by adding a leading proportional pressure valve, and pump flow can also be adjusted on the first pipe by adding an external feedback on the PF port as a control signal on the main stream.

- ※ Horse power setting, please following type code.
- ※ Proportional pressure max.250 bar.
If needing any other pressure range, please contact YEOSHE.

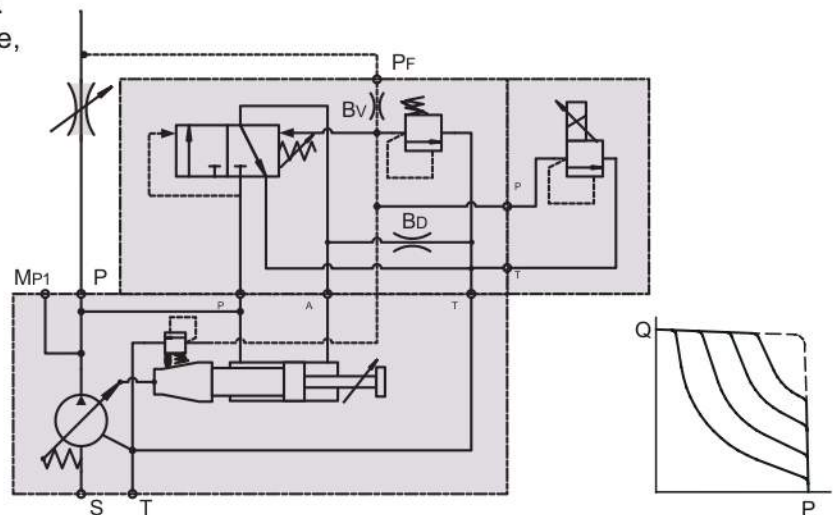



Horse power compensator, diagrams

A

34

PV Axial piston pump

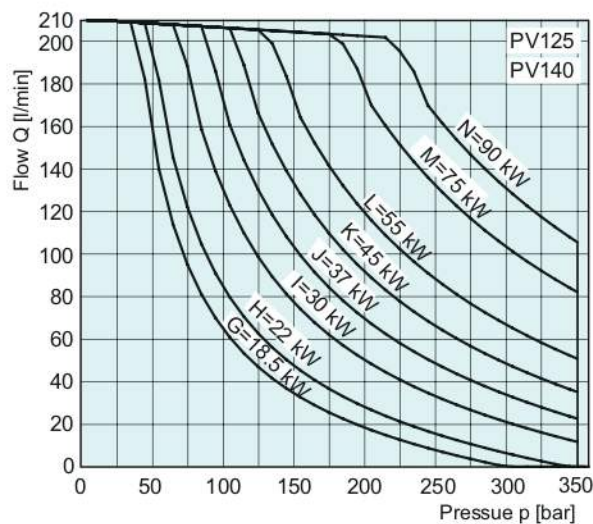
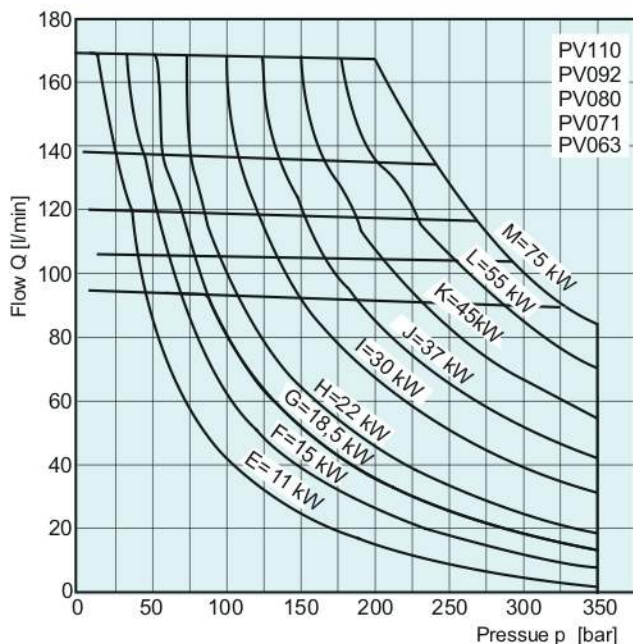
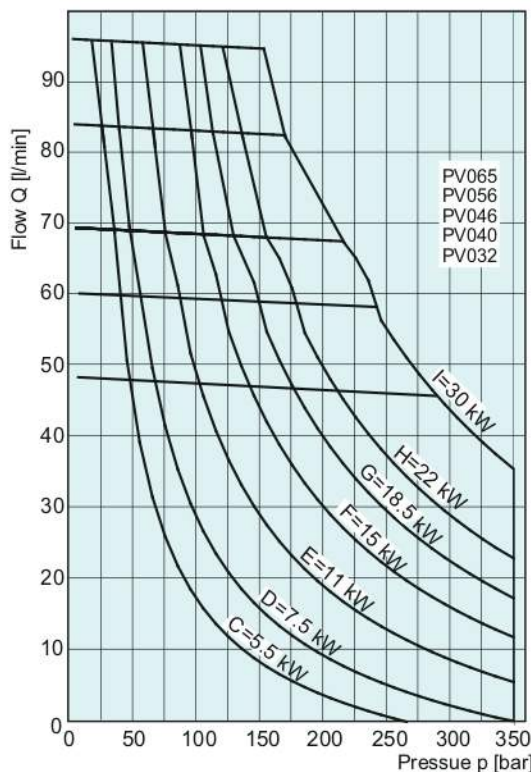
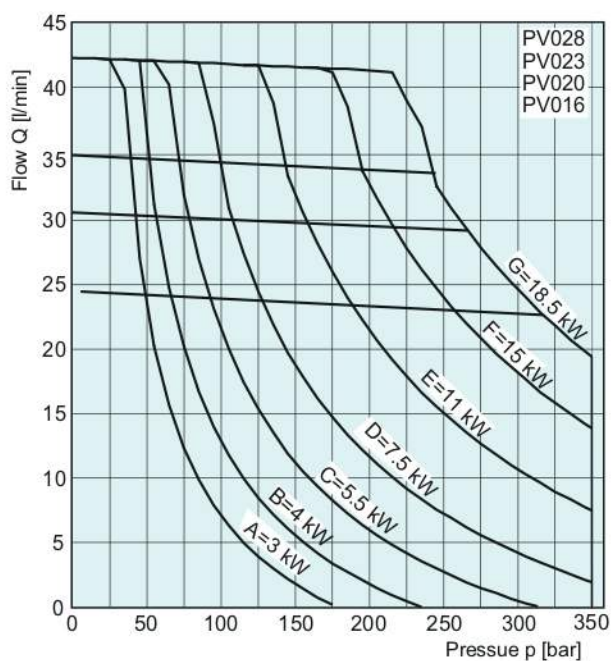

The diagrams are only valid for the following working conditions:
 speed: $n=1500$ (---) and 1800 (---) rev/min
 temperature: $t=50^{\circ}\text{C}$
 fluid: mineral oil HLP, ISO VG46
 viscosity: $\nu=46$ mm²/s at 40°C

Horse power compensator, diagrams

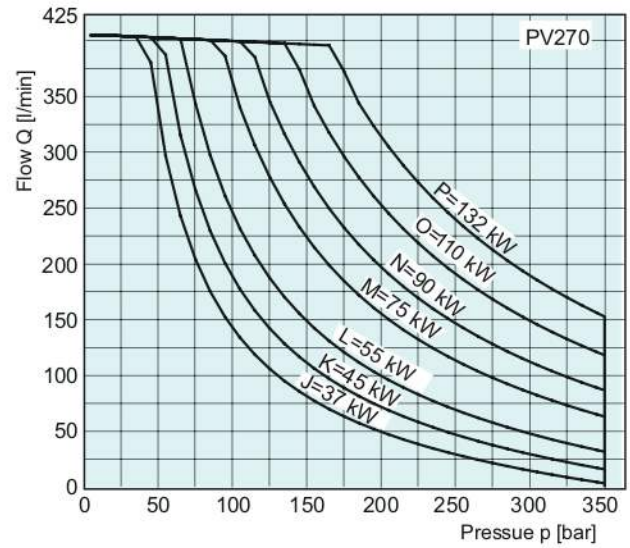
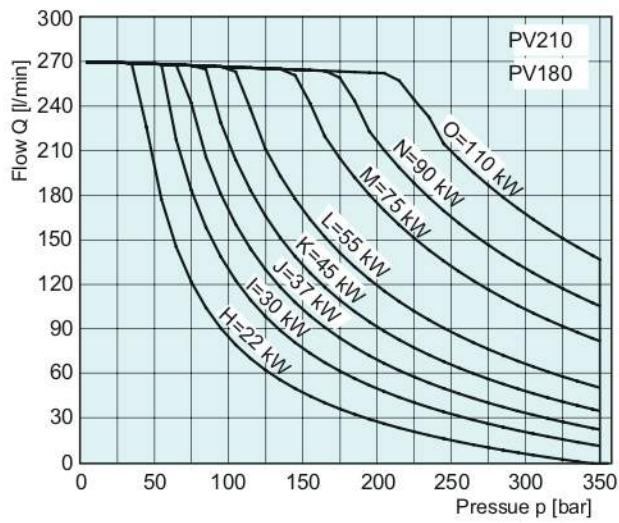

The diagrams are only valid for the following working conditions:
 speed: $n=1500$ (---) and 1800 (---) rev/min
 temperature: $t=50^{\circ}\text{C}$
 fluid: mineral oil HLP, ISO VG46
 viscosity: $v=46$ mm²/s at 40°C



Noise diagrams

A

36

PV Axial piston pump

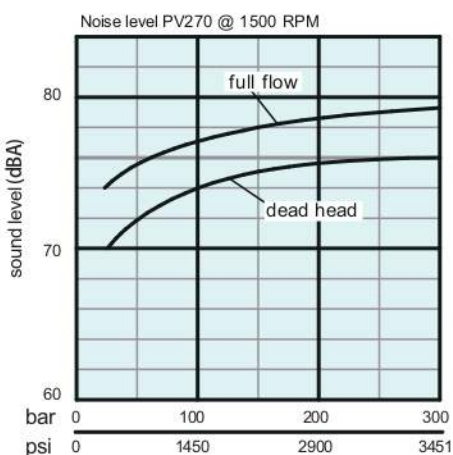
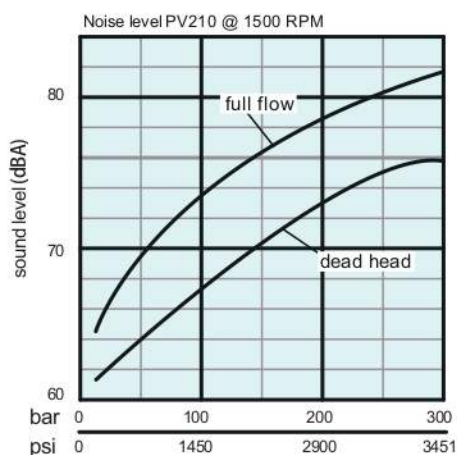
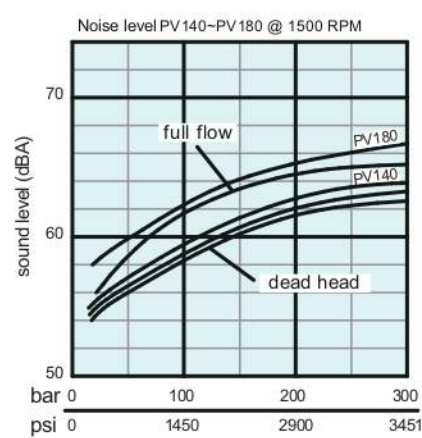
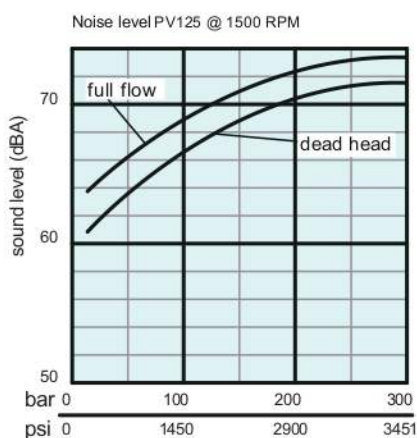
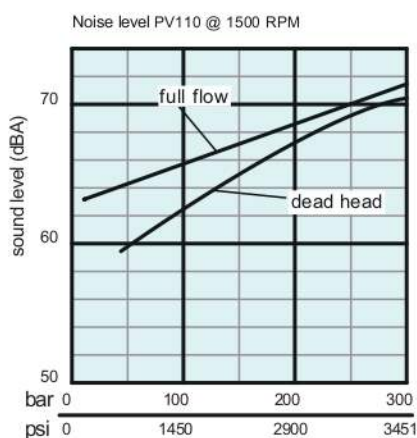
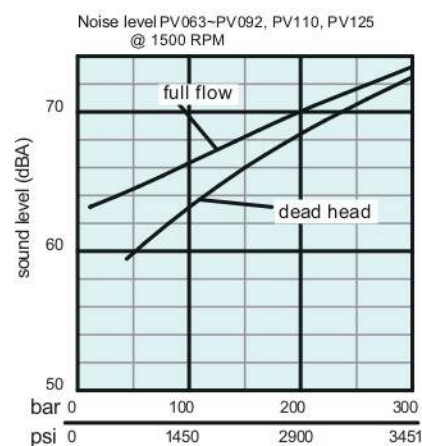
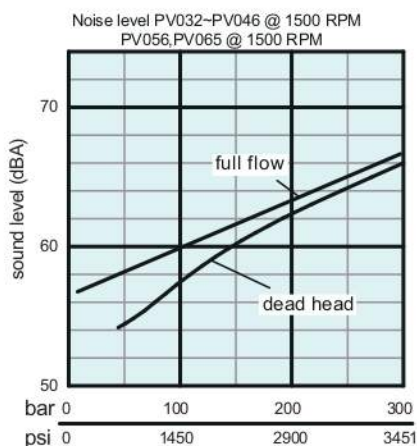
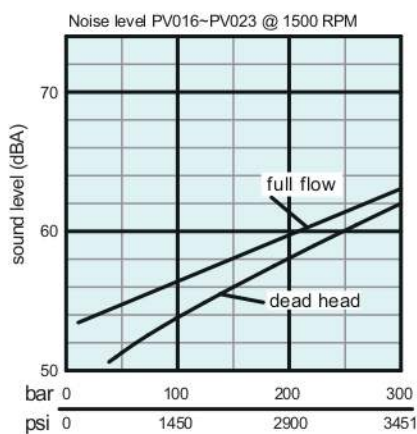

Test condition:

The noise of the single pump is according to the standard of DIN 45635, the rule of 1and26, at low echo measurement laboratory, measuring that the distance of microphone is 1m and 1500rpm.

Notice:

At the best time to install, the volume noise of hydraulic equipment is always 6 ~ 10 dBA higher than measuring at low echo measurement laboratory.

Proportional flow performance curves

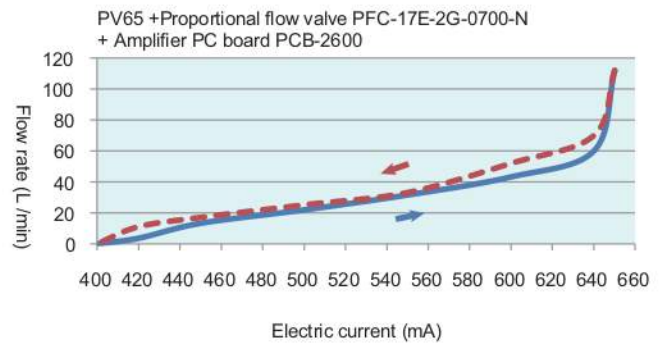
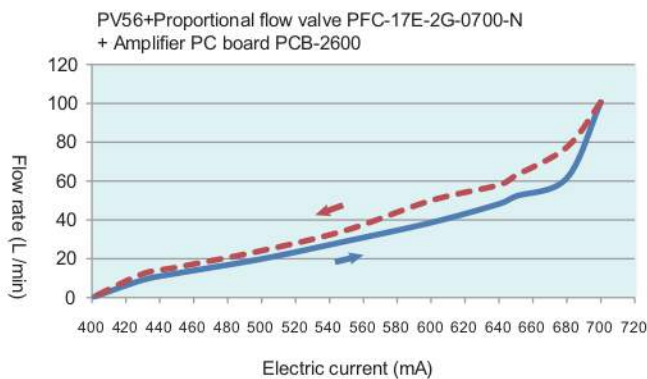
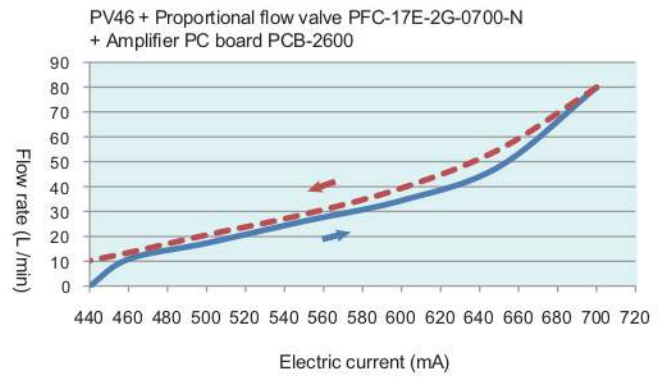
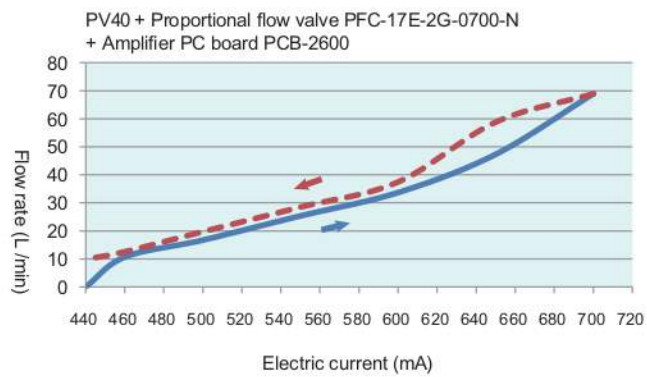
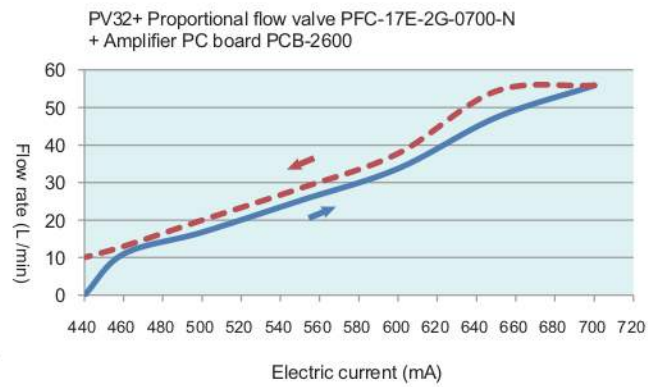
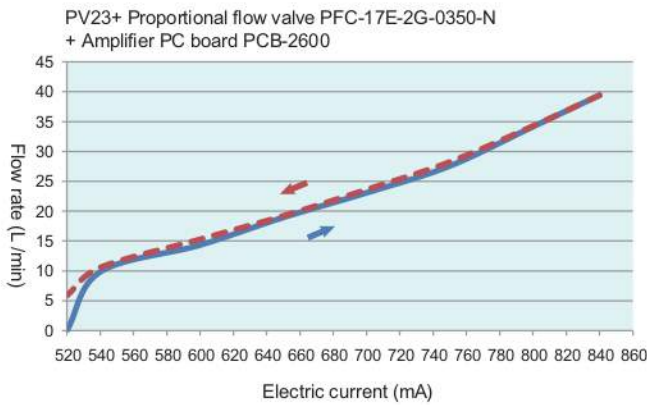
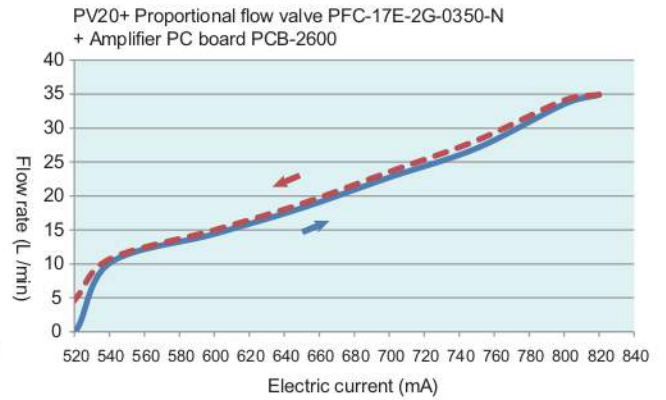
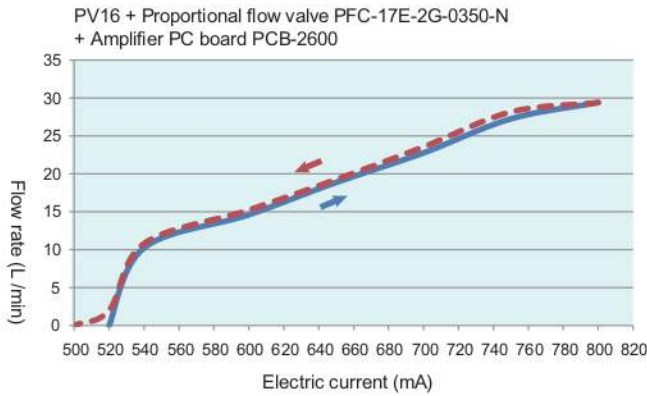



Proportional flow performance curves

A

38

PV Axial piston pump

PV63 + Proportional flow valve PFC-17E-2G-0700-N
+ Amplifier PC board PCB-2600

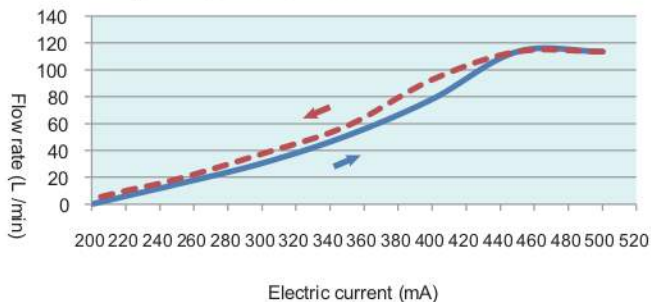

PV80 + Proportional flow valve PEV-16A-2D-09-N-1600
+ Amplifier PC board PCB-2600

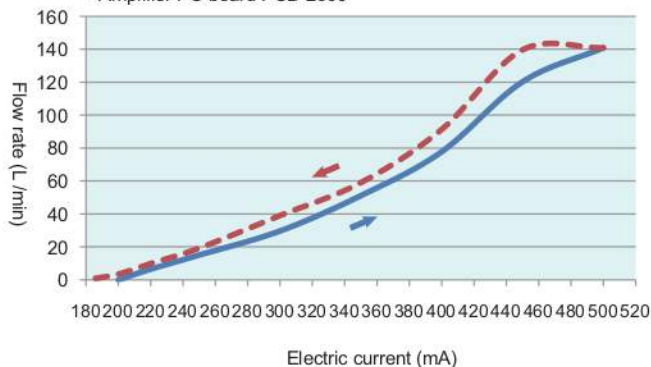

PV92 + Proportional flow valve PEV - 16A-2D-09-N-1600
+ Amplifier PC board PCB-2600

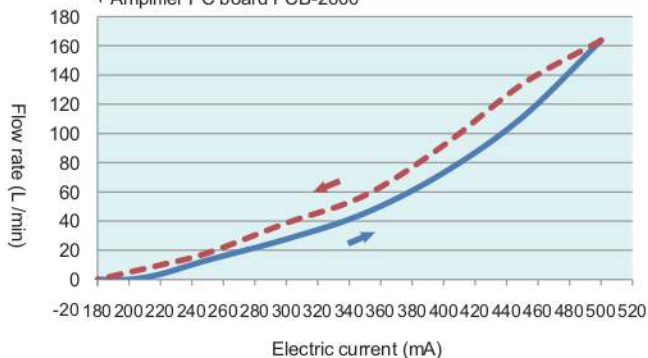

PV110 + Proportional flow valve PEV-16A-2D-09-N-1600
+ Amplifier PC board PCB-2600

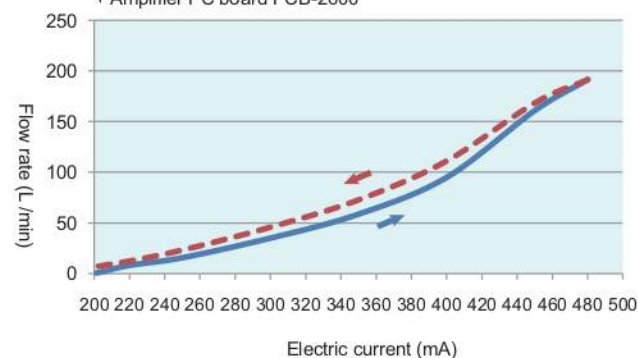

PV125 + Proportional flow valve PEV-16A-2D-09-N-1600
+ Amplifier PC board PCB-2600

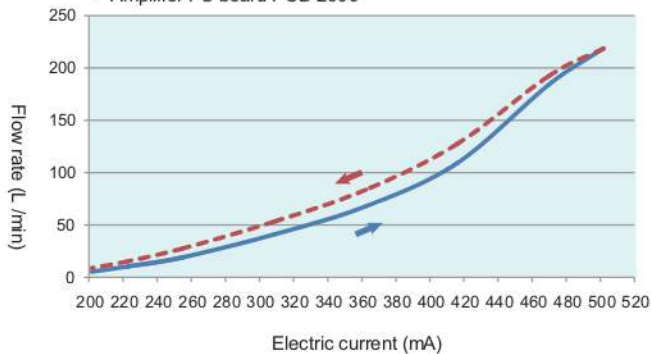

PV140 + Proportional flow valve PEV-18A-2D-09-N-3200
+ Amplifier PC board PCB-2600

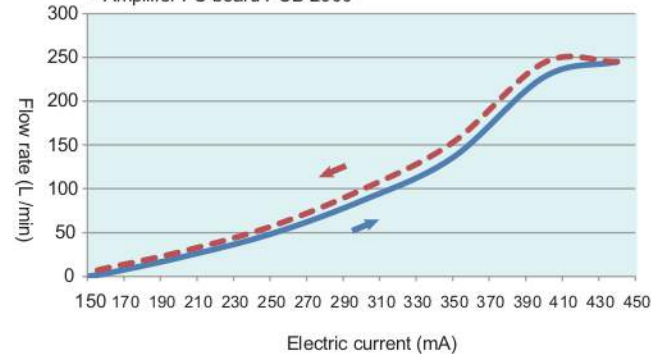

PV180 + Proportional flow valve PEV-18A-2D-09-N-3200
+ Amplifier PC board PCB-2600

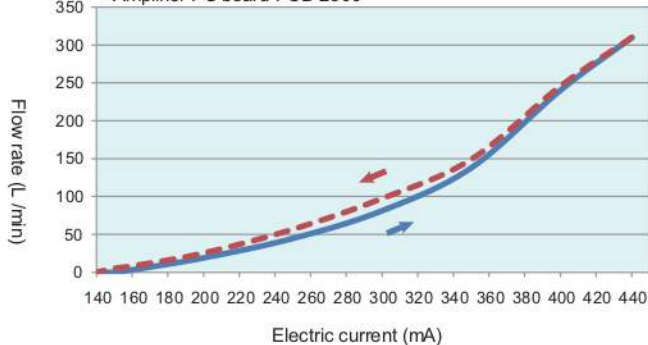

Proportional pressure performance curves

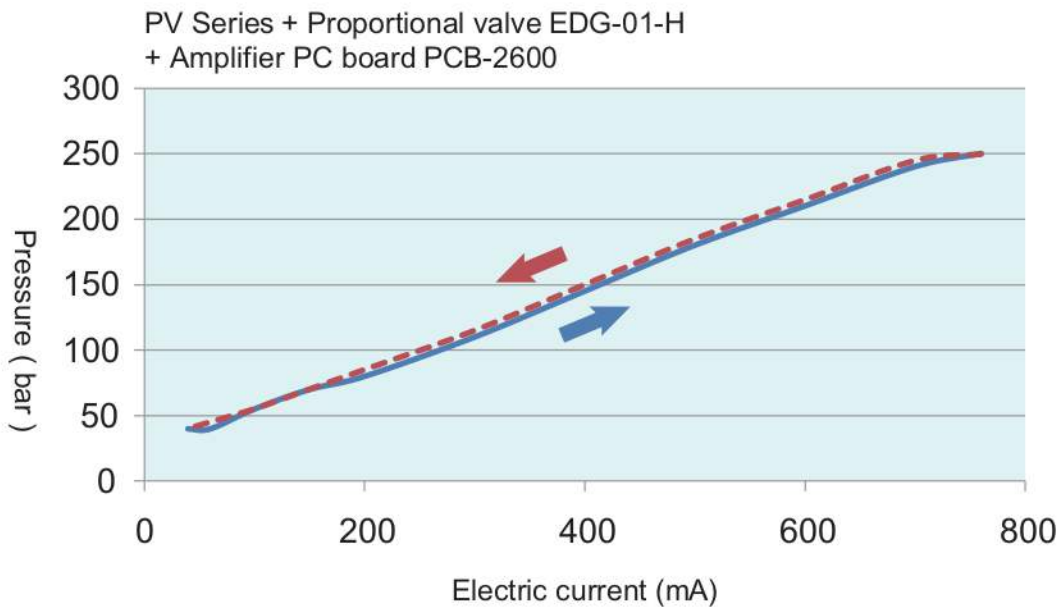



Proportional amplifier

PCB-2600

A

40

PV Axial piston pump

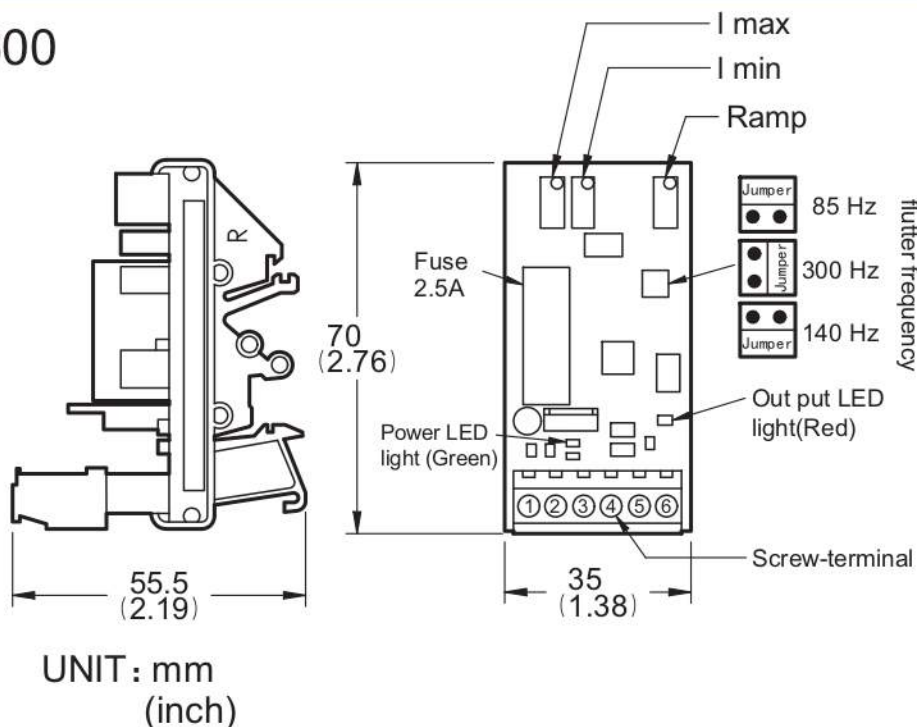

UNIT : mm
(inch)

Instructions for setting

Supply: green LED

RAMP: ramping up/down time adjustment. For long ramping times, turn potentiometers clockwise, for short ramping times, turn potentiometers counter-clockwise.

MAX/MIN:

I max / I min
There are multi-course potentiometers for adjustment of min-max and also ramp time.

Frequency ADJ.:

The dither frequency can be set with a jumper to 85, 140, or 300 Hz.

Technical data

Supply voltage: 10-35 VDC

Max. current: 0-2600 mA adjustable for 12 and 24 VDC (Output is a PWM-DC)

Min. current: 0-600 mA adjustable

Ramp adjustment: 0~5 Sec.

Dither frequency: 85, 140, 300 Hz to be set by jumper(Standard 140 Hz)

Ambient operating temperature: -15~140°F
-10~60°C

Weight: 0.05kg

NOTICE

Do not remove the amplifier from the coil while the power is on. This will cause a failure in the internal circuits of the amplifier, resulting in loss of output to the coil.

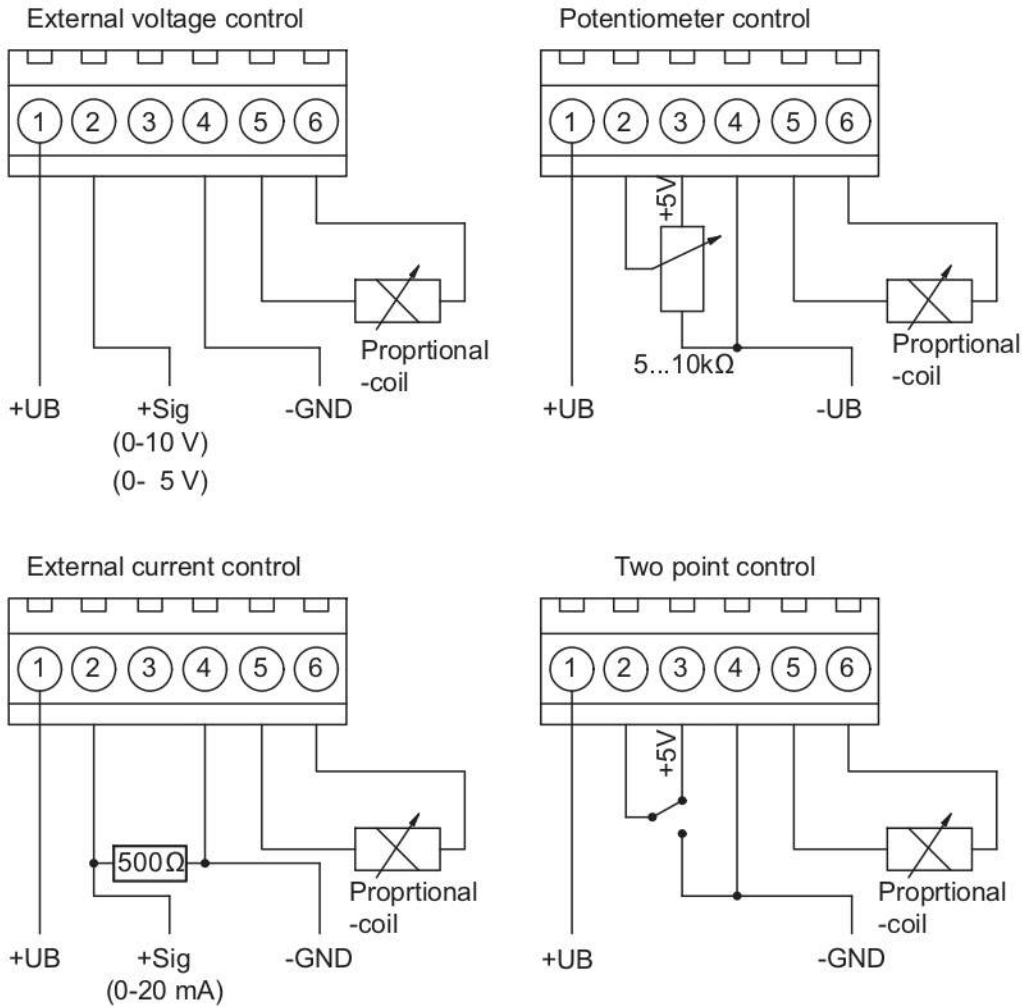

- . Clamp connections plug in connector
- Pin 1 =+ UB; supply voltage (10-35 VDC)
- Pin 2 = Control voltage (+ Sig)
- Pin 3 = Auxiliary voltage (+ 5 VDC)
- Pin 4 = Ground (GND)
- Pin 5 = Solenoid (-)
- Pin 6 = Solenoid (+)

- . Potentiometer
- Turn clockwise means increasing current or Extension of ramp time
- App. 10 turns for complete range

- .Fuse
- Standard 20 mm Glass fuse 2.5 A T

- .LED's
- LED +VS (green) = lights, when voltage supply and fuse are in order
- LED1 (red) = lights, if there is an output to the solenoid

Efficiency and case drain flows

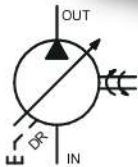

**PV125 ~ PV180
PV210 (Body 4)**

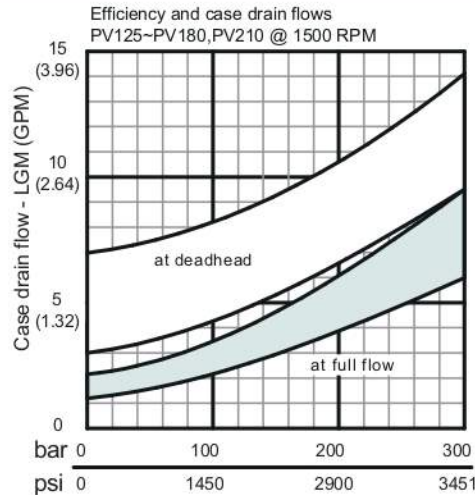

The efficiency and power graphs are measured at an input speed of $n = 1500$ RPM, a temperature of 40°C and a fluid viscosity of $46 \text{ mm}^2/\text{s}$.

Case drain flow and compensator control flow leave via the drain port of the pump.

To the values shown are to be added 1 to 1.2 l/min, if at pilot operated compensators (codes G*, H*, P*, horse power compensator and p/Q*control) the control flow of the pressure pilot valve also goes through the pump. Please note: The values shown below are only valid for static operation.

Under dynamic conditions and at rapid compensation of the pump the volume displaced by the servo piston also leaves the case drain port.

This dynamic control flow can reach up to 40 l/min! Therefore the case drain line is to lead to the reservoir at full size and without restrictions as short and direct as possible.

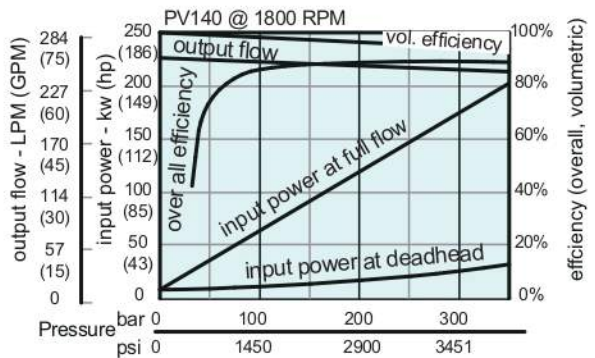
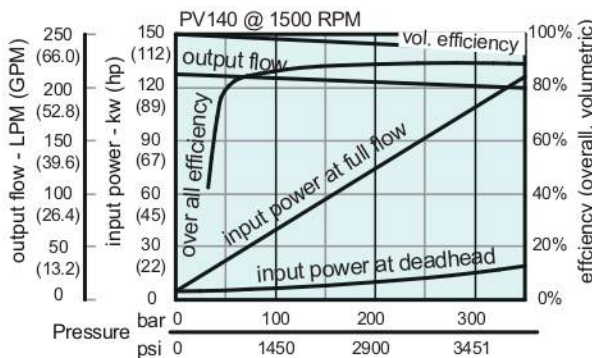
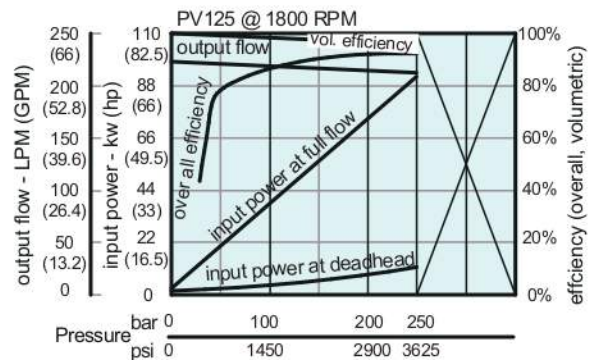
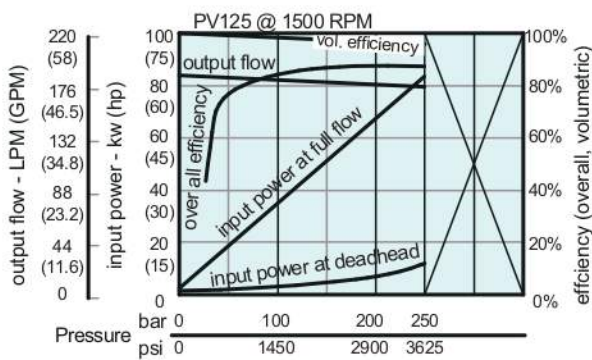



Efficiency and case drain flows



PV125 ~ PV180
PV210 (Body 4)

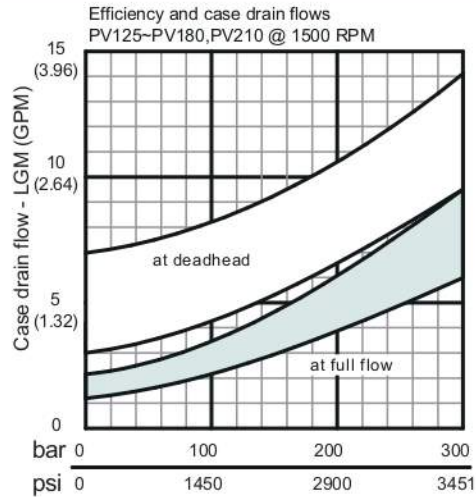

The efficiency and power graphs are measured at an input speed of $n = 1500$ RPM, a temperature of 40°C and a fluid viscosity of $46 \text{ mm}^2/\text{s}$.

Case drain flow and compensator control flow leave via the drain port of the pump.

To the values shown are to be added 1 to 1.2 l/min, if at pilot operated compensators (codes G*, H*, P*, horse power compensator and p/Q* control) the control flow of the pressure pilot valve also goes through the pump.

Please note: The values shown below are only valid for static operation.

Under dynamic conditions and at rapid compensation of the pump the volume displaced by the servo piston also leaves the case drain port.

This dynamic control flow can reach up to 40 l/min! Therefore the case drain line is to lead to the reservoir at full size and without restrictions as short and direct as possible.

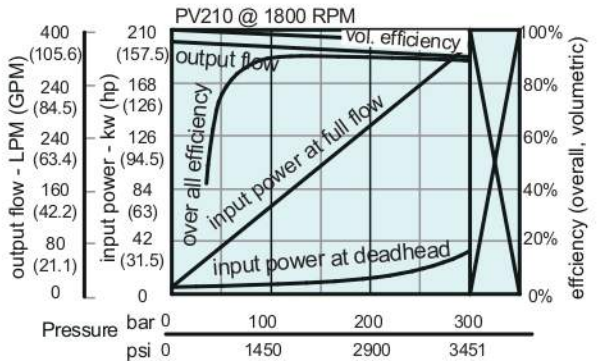
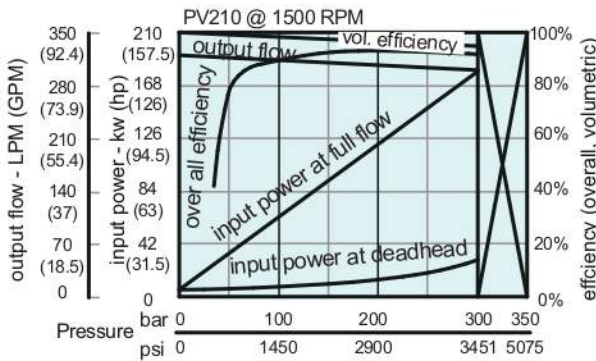
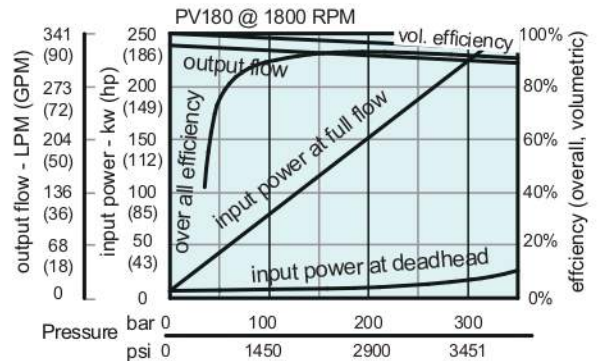
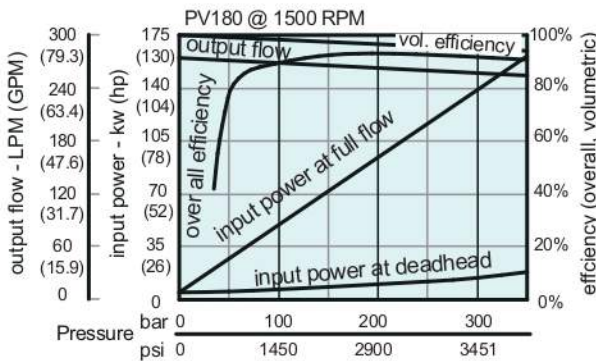

Dimension

PV125 ~ PV180, PV210 (Body 4)

Metric version (motor mounting Ø160)

Mounting hole for horse power compensator pilot or displacement feedback LVDT

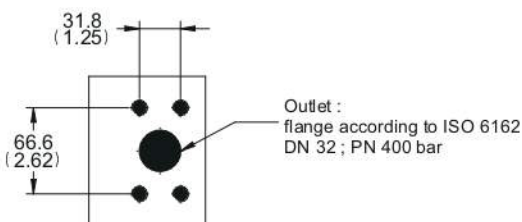
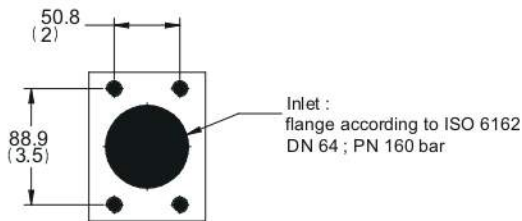
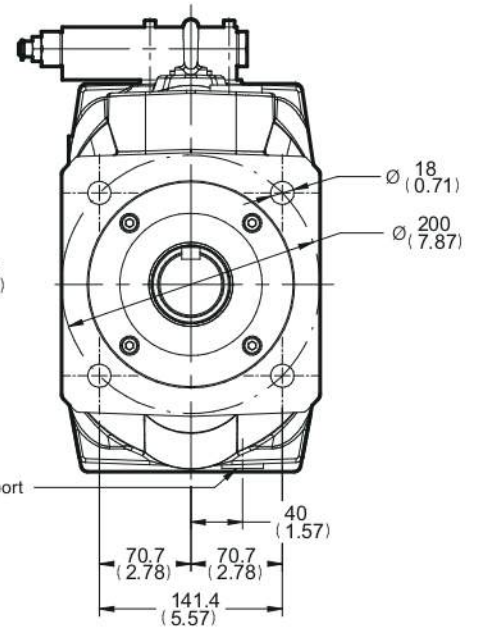
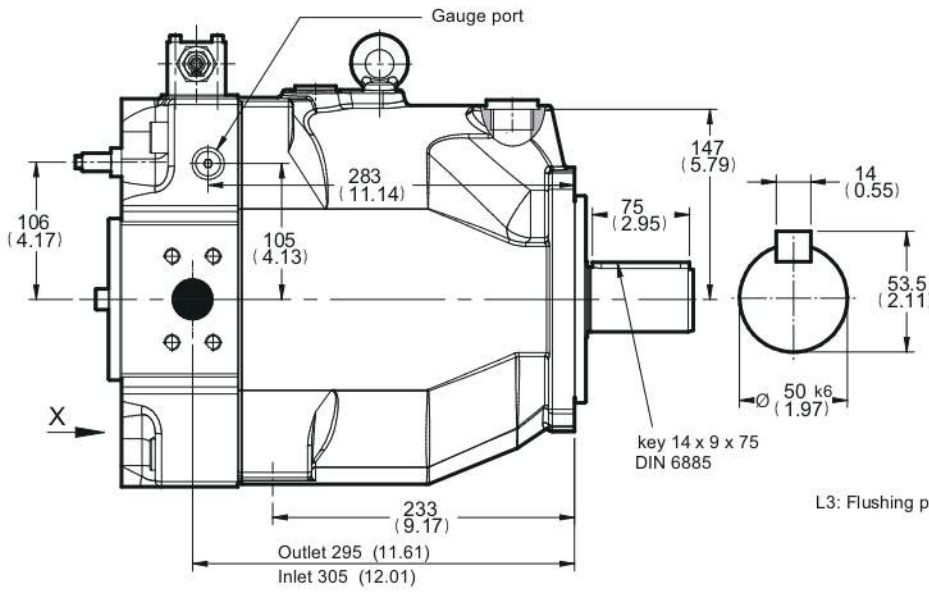
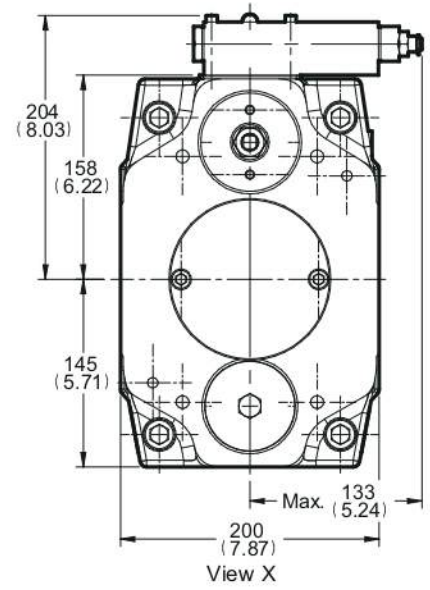
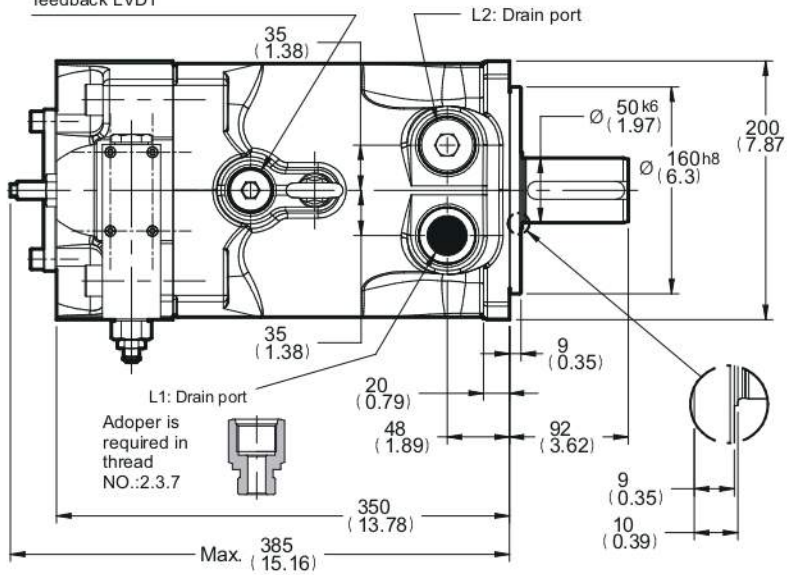

Ports	3	1	2	7
Thread	UNF(SAE)	BSPP(G)	PT(RC)	ISO 6149(M)
Inlet	Ø64 1/2"-13 UNC 20 deep	Ø64 M12*P1.75 20 deep	Ø64 M12*P1.75 20 deep	Ø64 M12*P1.75 20 deep
Outlet	Ø32 1/2"-13 UNC 20 deep	Ø32 M12*P1.75 20 deep	Ø32 M12*P1.75 20 deep	Ø32 M12*P1.75 20 deep
Drain port (L1/ L2)	1 5/16"-12 UNF	G 1"-11	PT 1"-11	M33*P2.0
L3	1 1/16"-12 UNF	G 3/4"-14	PT 3/4"-14	M27*P2.0
Gauge port	7/16"-20 UNF	G 1/4"-19	PT 1/4"-19	M12*P1.5

threads code: 3 & 7 are not standard, not it stock, specially fabricate.

Adoper is required in thread NO.:2.3.7 (Drain port)





Dimension

PV125 ~ PV180, PV210 (Body 4)

Metric version (motor mounting $\varnothing 160$)

Shaft type

A

68

PV Axial piston pump

Mounting code: **M**

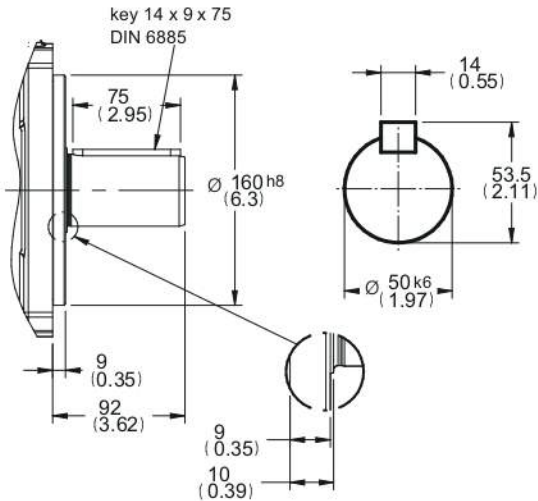

Mounting code: **R**

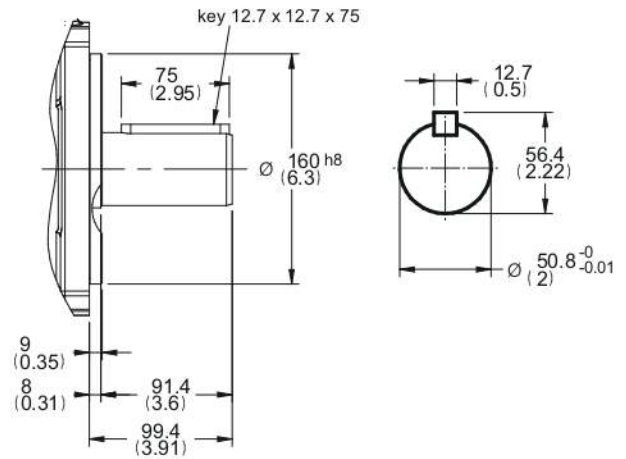

Mounting code: **K**

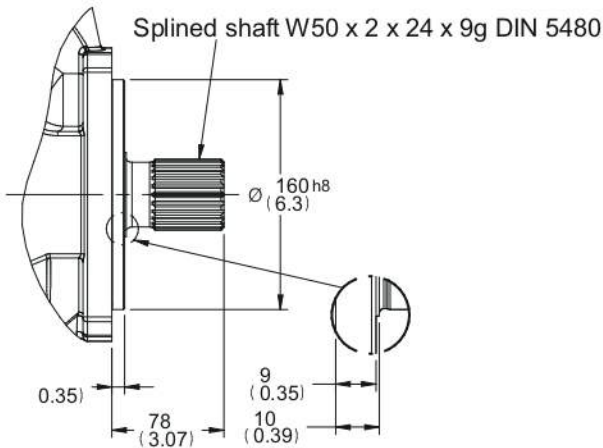

Mounting code: **S**

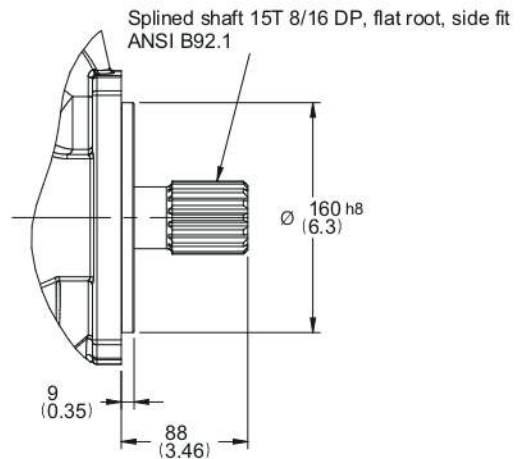

Mounting code: **Q**

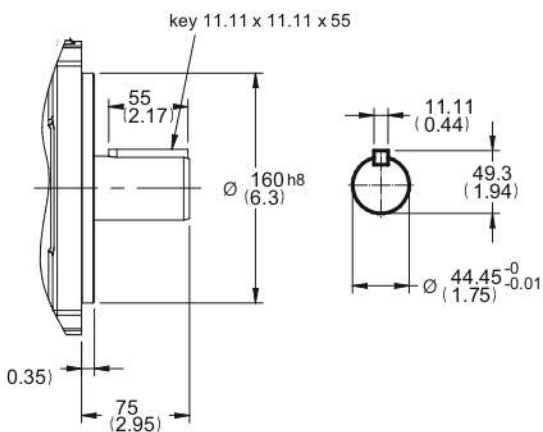

Mounting code: **P**

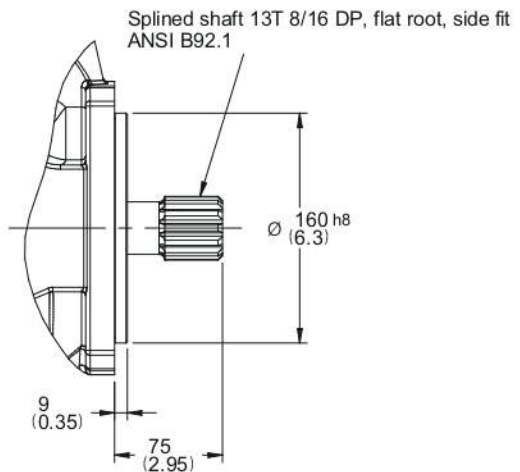

Dimension

PV125 ~ PV180, PV210 (Body 4)
SAE version (motor mounting Ø152.4)

A

69

PV Axial piston pump

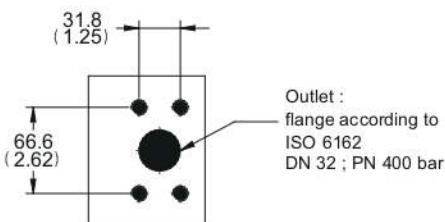
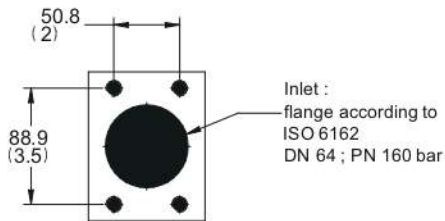
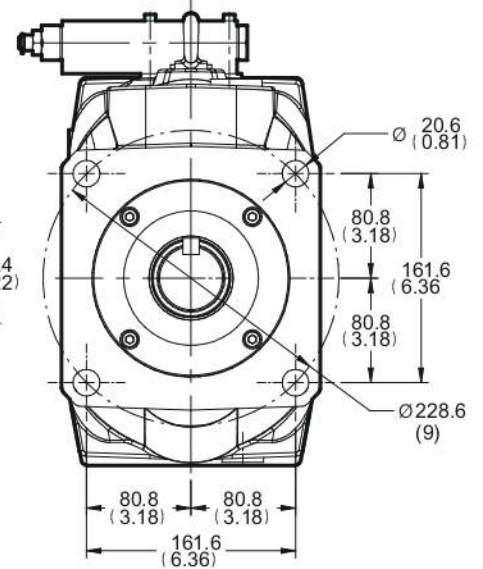
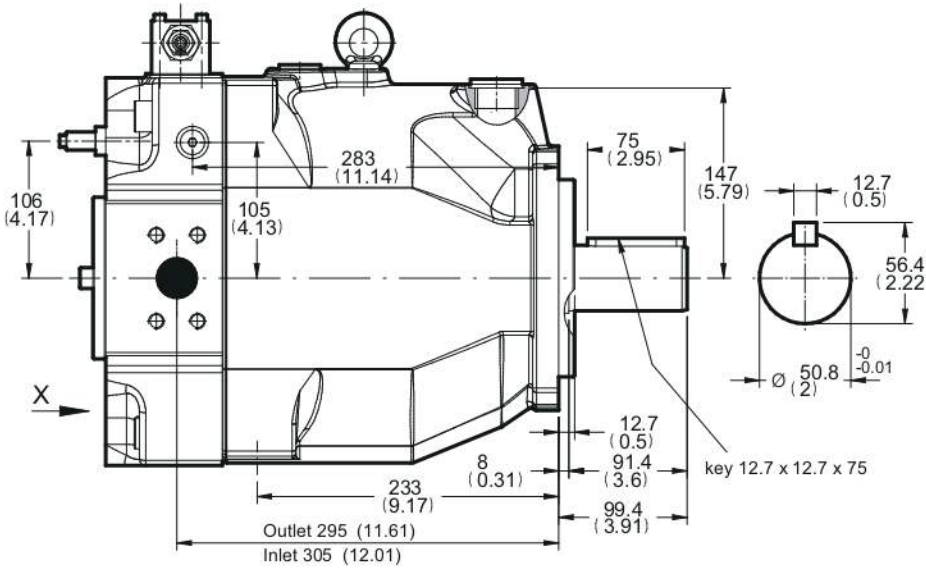
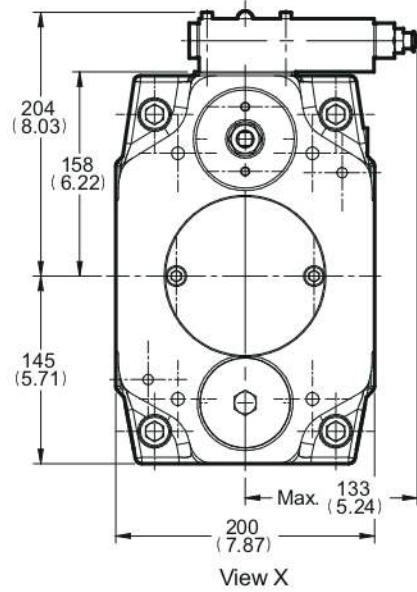
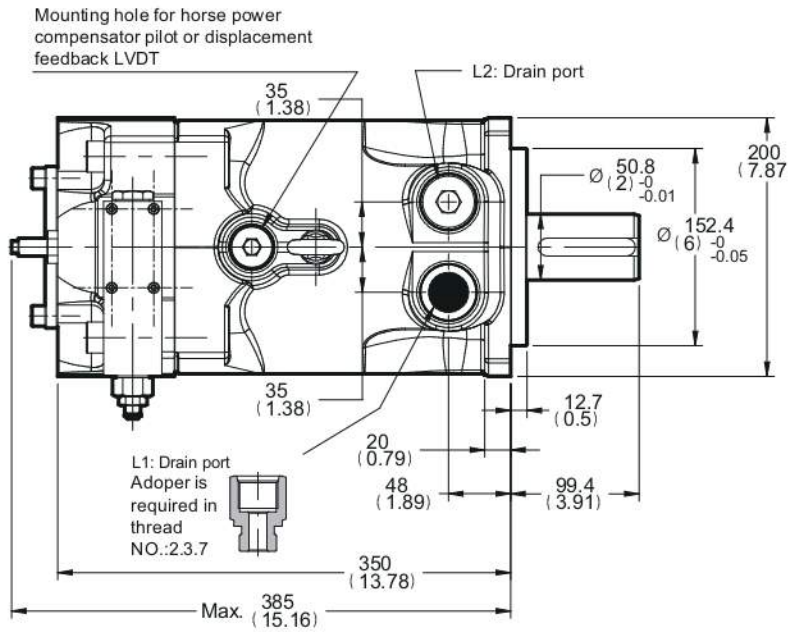

Ports

Thread	1	2	3	7
	BSPP(G)	PT(RC)	UNF(SAE)	ISO 6149(M)
Inlet	Ø64 M12*P1.75 20 deep	Ø64 M12*P1.75 20 deep	Ø64 1/2"-13 UNC 20 deep	Ø64 M12*P1.75 20 deep
Outlet	Ø32 M12*P1.75 20 deep	Ø32 M12*P1.75 20 deep	Ø32 1/2"-13 UNC 20 deep	Ø32 M12*P1.75 20 deep
Drain port (L1/ L2)	G 1"-11	PT 1"-11	1 5/16"-12 UNF	M33*P2.0
L3	G 3/4"-14	PT 3/4"-14	1 1/16"-12 UNF	M27*P2.0
Gauge port	G 1/4"-19	PT 1/4"-19	7/16"-20 UNF	M12*P1.5

threads code: 3 & 7 are not standard, not it stock, specially fabricate.
Adoper is required in thread NO.:2.3.7 (Drain port)





Dimension

PV125 ~ PV180, PV210 (Body 4)

SAE version(motor mounting Ø152.4)

Shaft type

A

70

PV Axial piston pump

Mounting code: **N**

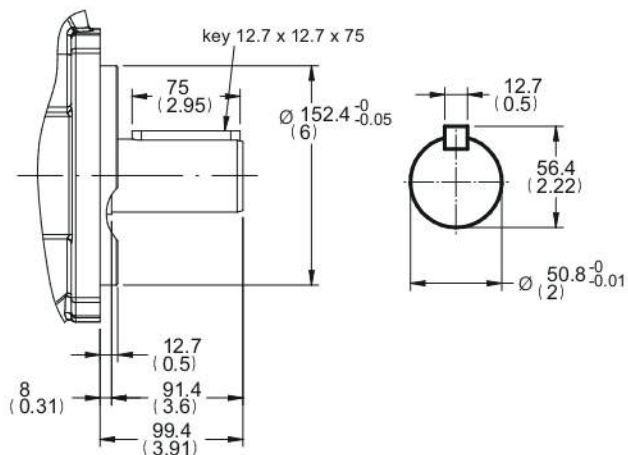

Mounting code: **J**

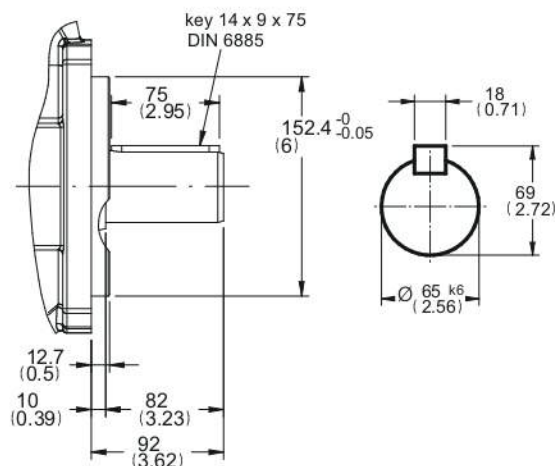

Mounting code: **D**

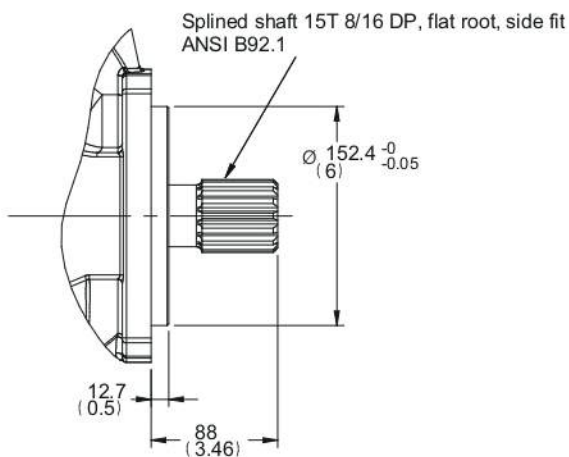

Mounting code: **U**

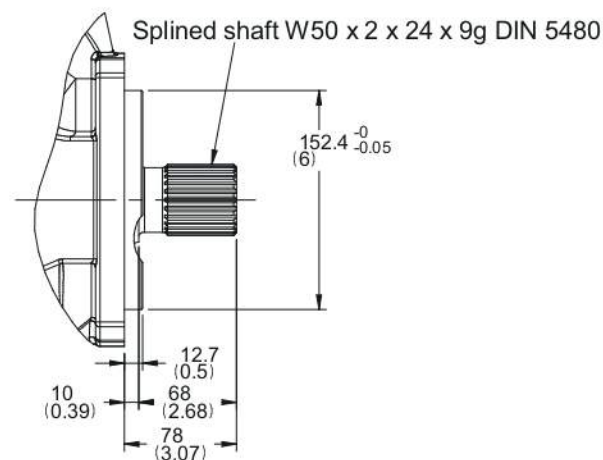

Mounting code: **G**

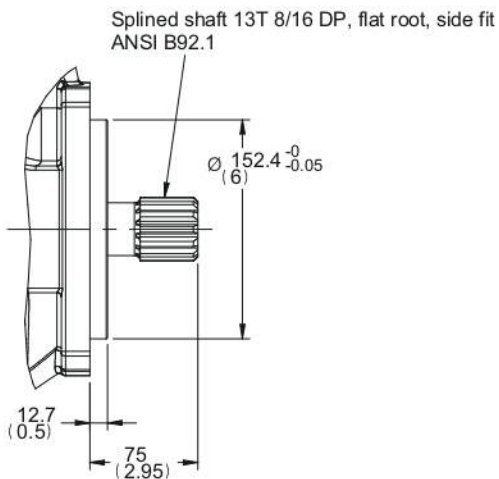

Mounting code: **F**

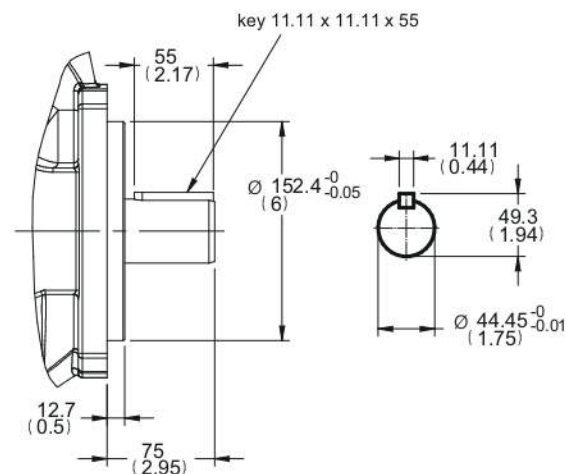

Dimension

PV125 ~ PV180, PV210 (Body 4)

Thru drive

Thru drive:

D, E, F, G, J, K, L, M

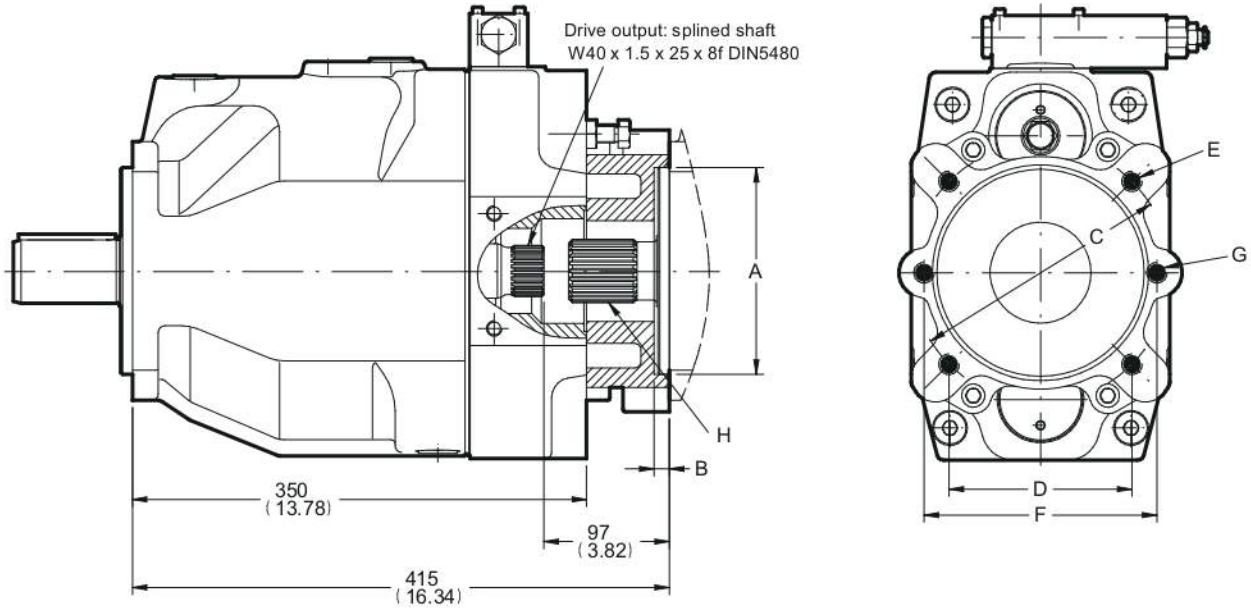

A

71

PV Axial piston pump

Thru shaft adaptors are available with the following dimensions:

thru code	A	B	C	D	E	F	G
J	80	10	103	-	M8	109	M10
K	100	12	125	-	M10	140	M12
L	125	12	160	-	M12	180	M16
M	160	12	200	-	M16	n. avail.	n. avail.
D	82.55	10	-	-	-	106	M10
E	101.6	12	-	89.8	M10	146	M12
F	127	14	-	114.5	M12	181	M16
G	152.4	14	-	161.6	M16	n. avail.	n. avail.

Thread codes are 3 and 7 the dimensions E and G are UNC-2B threads

threads code: 3 and 7 Not standard, not in stock require special requests.





Dimension

PV125 ~ PV180, PV210 (Body 4) Inlet / Outlet Flange

A

72

PV Axial piston pump

Inlet Flange

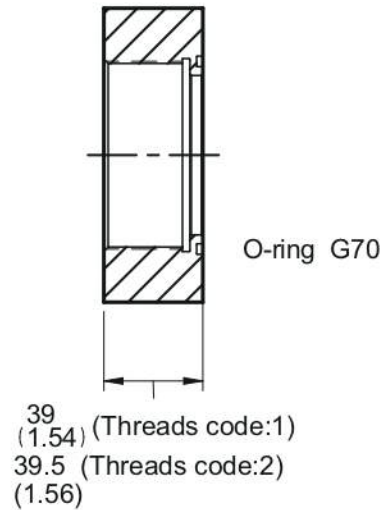
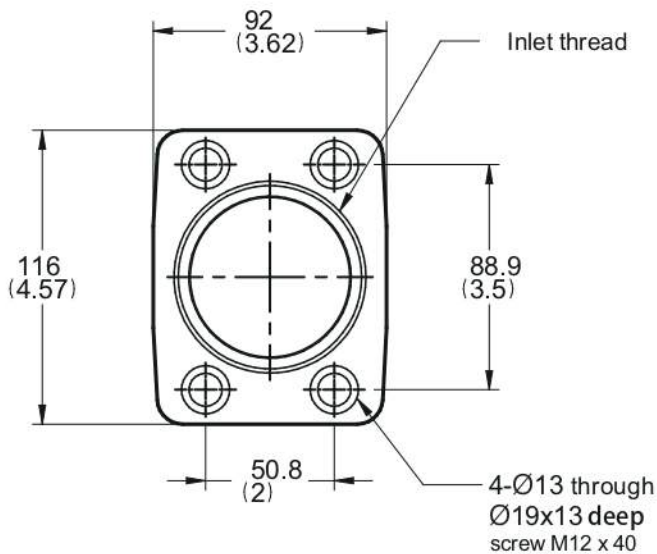

Outlet Flange

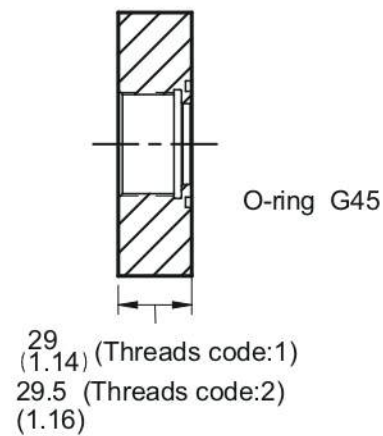
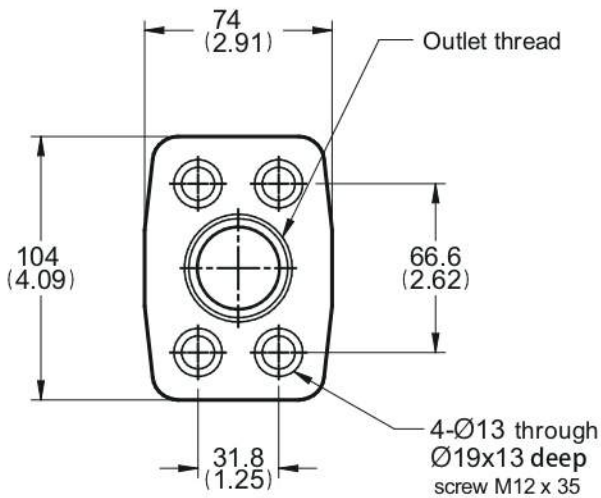

Ports

Thread code	3	1	2	7
	UNF(SAE)	BSPP(G)	PT(RC)	ISO 6149(M)
Inlet	Welding	G 2 1/2"-11	PT 2 1/2"-11	Welding
Outlet	1 5/8"-12 UN	G 1 1/4"-11	PT 1 1/4"-11	M42*P2.0

threads code: 3 & 7 are not standard, not it stock, specially fabricate.

Efficiency and case drain flows

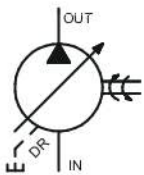

PV270 (Body 5)

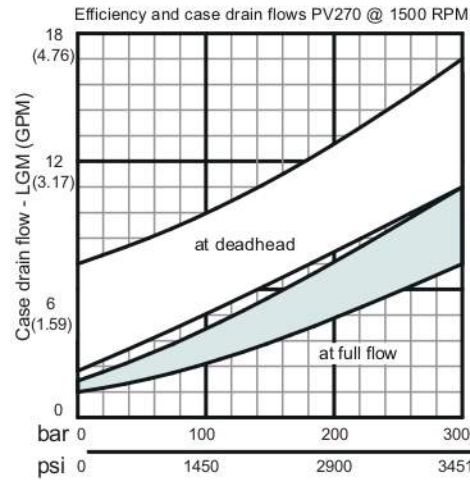

The efficiency and power graphs are measured at an input speed of $n = 1500$ RPM, a temperature of 40°C and a fluid viscosity of $46 \text{ mm}^2/\text{s}$.

Case drain flow and compensator control flow leave via the drain port of the pump.

To the values shown are to be added 1 to 1.2 l/min, if at pilot operated compensators (codes G*, H*, P*, horse power compensator and p/Q(control) the control flow of the pressure pilot valve also goes through the pump.

Please note: The values shown below are only valid for static operation.

Under dynamic conditions and at rapid compensation of the pump the volume displaced by the servo piston also leaves the case drain port.

This dynamic control flow can reach up to 120 l/min!

Therefore the case drain line is to lead to the reservoir at full size and without restrictions as short and direct as possible.

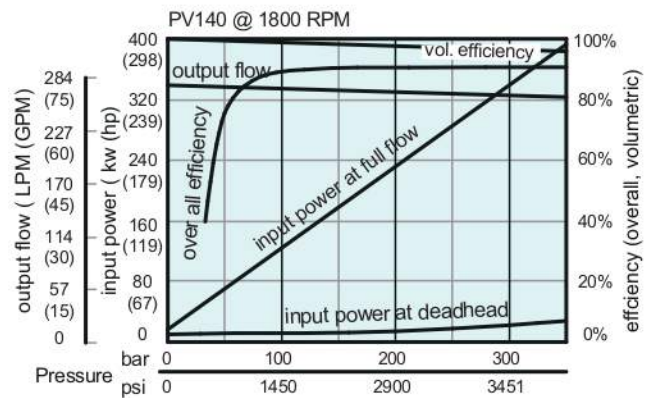
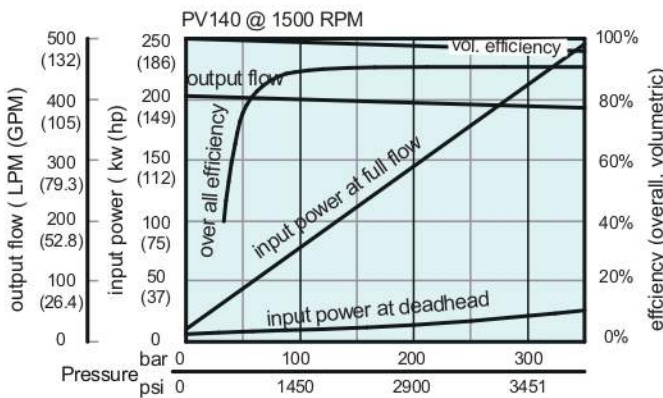



Dimension

PV270 (Body5)

Metric version (motor mounting Ø200)

A

74

PV Axial piston pump

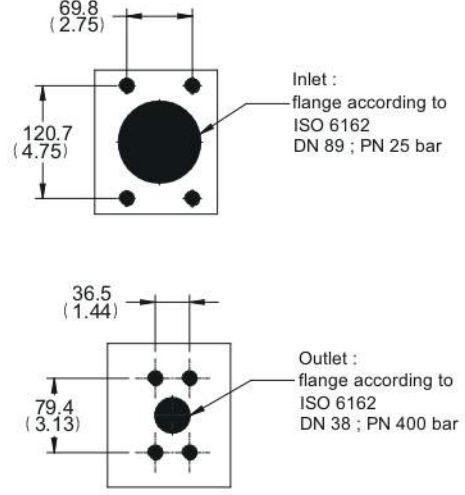
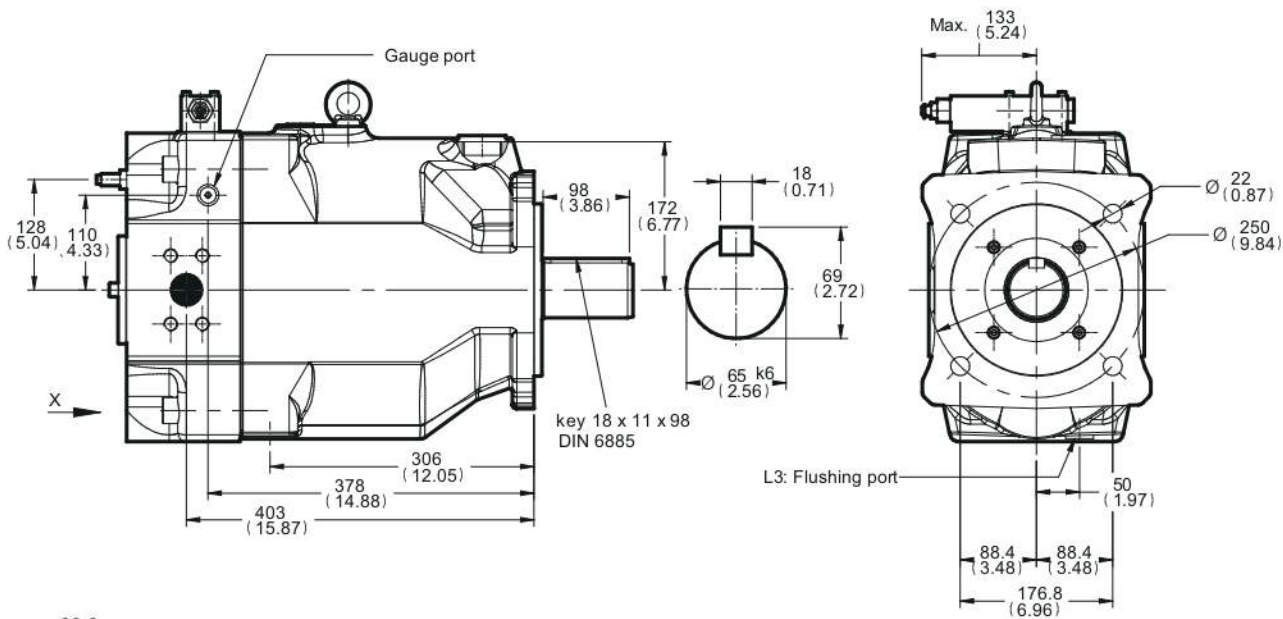
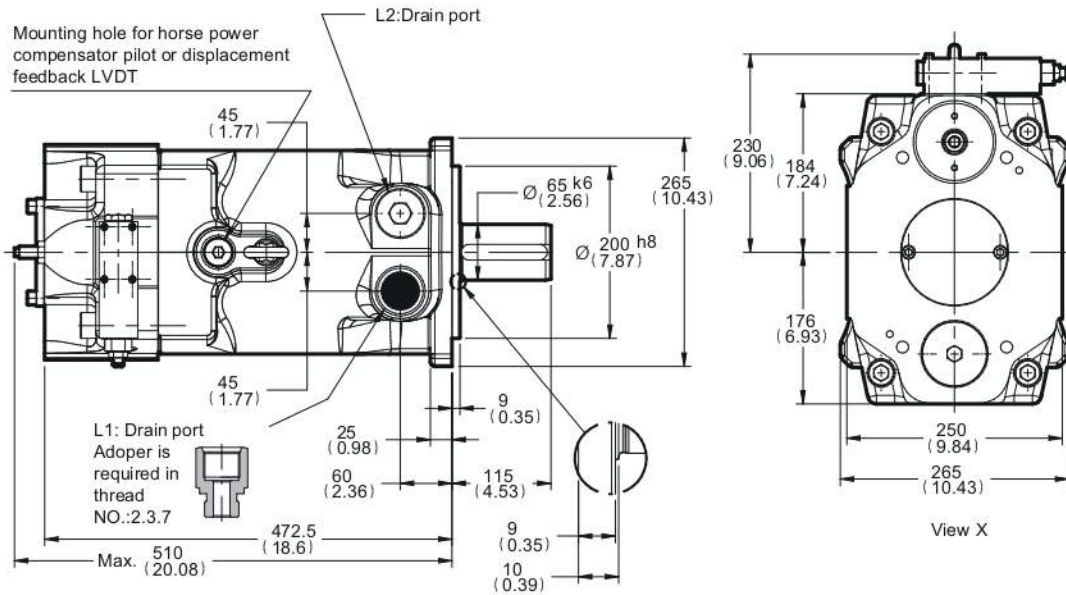

Ports	3	1	2	7
Thread	UNF(SAE)	BSPP(G)	PT(RC)	ISO 6149(M)
Inlet	Ø88 5/8"-11 UNC 32 deep	Ø88 M16*P2.0 32 deep	Ø88 M16*P2.0 32 deep	Ø88 M16*P2.0 32 deep
Outlet	Ø38 5/8"-11 UNC 32 deep	Ø38 M16*P2.0 32 deep	Ø38 M16*P2.0 32 deep	Ø38 M16*P2.0 32 deep
Drain port (L1/ L2)	1 5/8"-12 UNF	G 1 1/4"-11	PT 1 1/4"-11	M42*P2.0
L3	1 1/16"-12 UNF	G 3/4"-14	PT 3/4"-14	M27*P2.0
Gauge port	7/16"-20 UNF	G 1/4"-19	PT 1/4"-19	M12*P1.5

threads code: 3 & 7 are not standard, not it stock, specially fabricate.
Adoper is required in thread NO.:2.3.7 (Drain port)

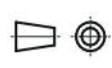

Dimension

PV270 (Body 5)

Metric version (motor mounting Ø200)

Shaft type

A
75

PV Axial piston pump

Mounting code: **M**

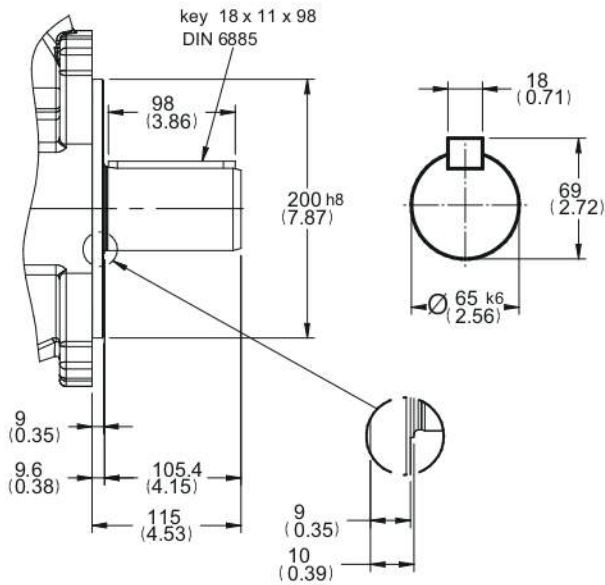

Mounting code: **R**

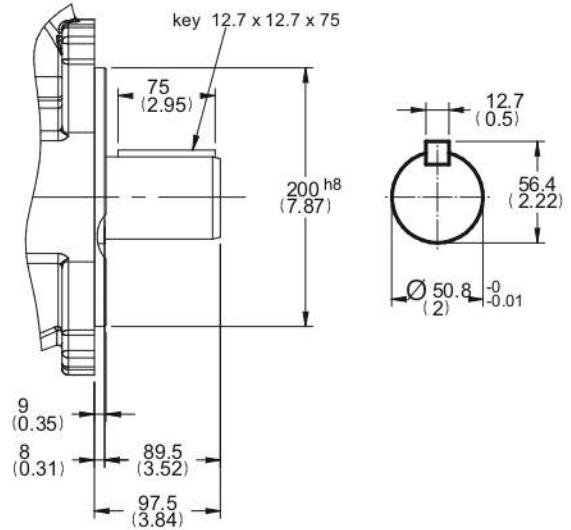

Mounting code: **K**

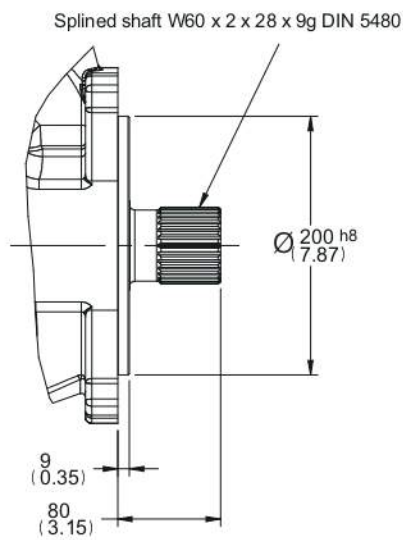

Mounting code: **S**

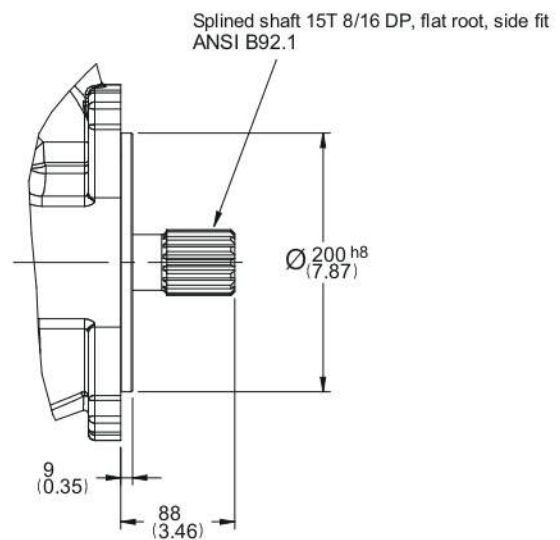



Dimension

PV270 (Body 5)

SAE version (motor mounting Ø165.1)

A

76

PV Axial piston pump

Mounting hole for horse power compensator pilot or displacement feedback LVDT

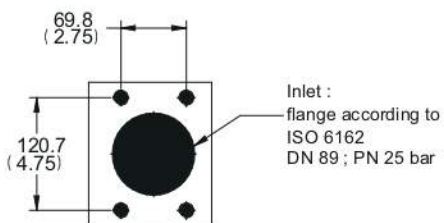
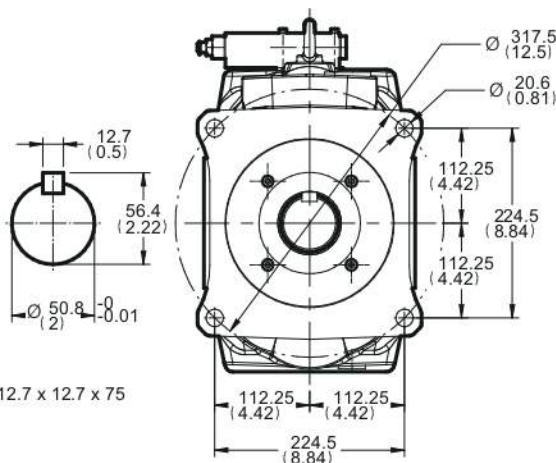
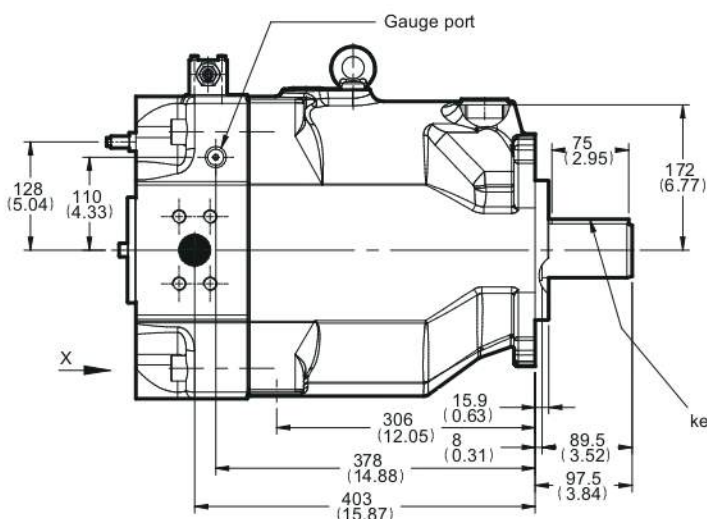
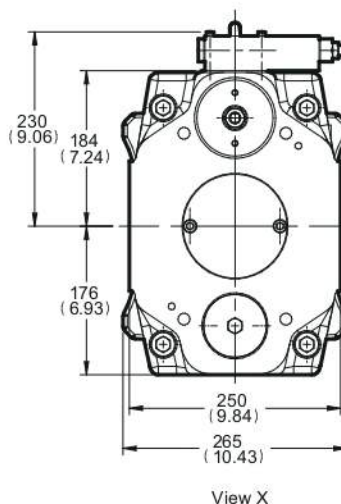
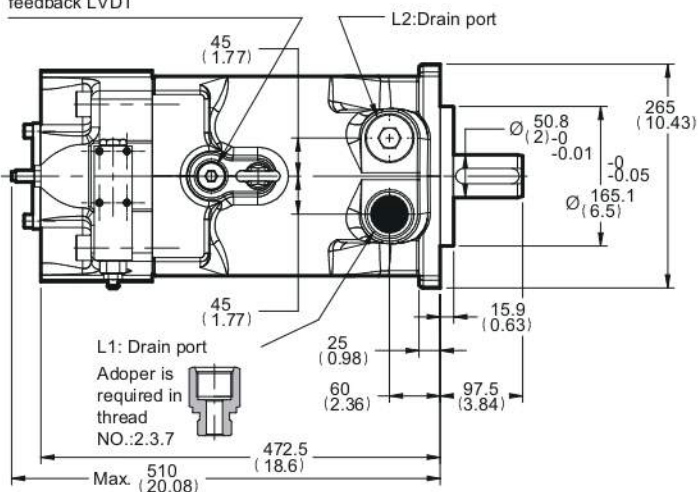

Inlet :
flange according to
ISO 6162
DN 89 ; PN 25 bar

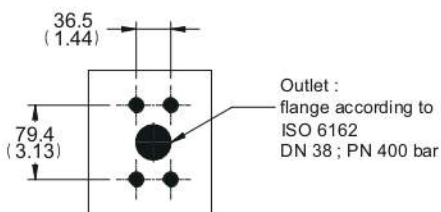

Outlet :
flange according to
ISO 6162
DN 38 ; PN 400 bar

Ports

Thread	3	1	2	7
	UNF(SAE)	BSPP(G)	PT(RC)	ISO 6149(M)
Inlet	Ø88 5/8"-11 UNC	Ø88 M16*P2.0	Ø88 M16*P2.0	Ø88 M16*P2.0
Outlet	32 deep Ø38 5/8"-11 UNC	32 deep Ø38 M16*P2.0	32 deep Ø38 M16*P2.0	32 deep Ø38 M16*P2.0
Drain port (L1/ L2)	1 5/8"-12 UNF	G 1 1/4"-11	PT 1 1/4"-11	M42*P2.0
L3	1 1/16"-12 UNF	G 3/4"-14	PT 3/4"-14	M27*P2.0
Gauge port	7/16"-20 UNF	G 1/4"-19	PT 1/4"-19	M12*P1.5

Threads code: 3 & 7 are not standard, not it stock, specially fabricate.
Adoper is required in thread NO.:2.3.7 (Drain port)



Dimension

PV270 (Body 5)

SAE version(motor mounting $\text{Ø}165.1$)

Shaft type

Mounting code: **N**

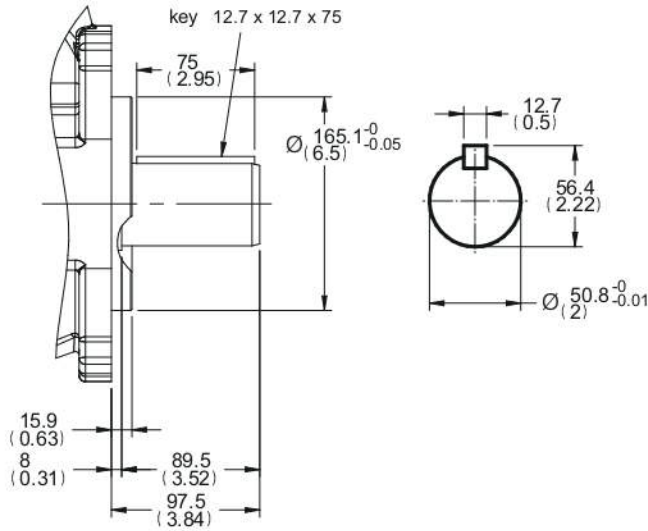

Mounting code: **J**

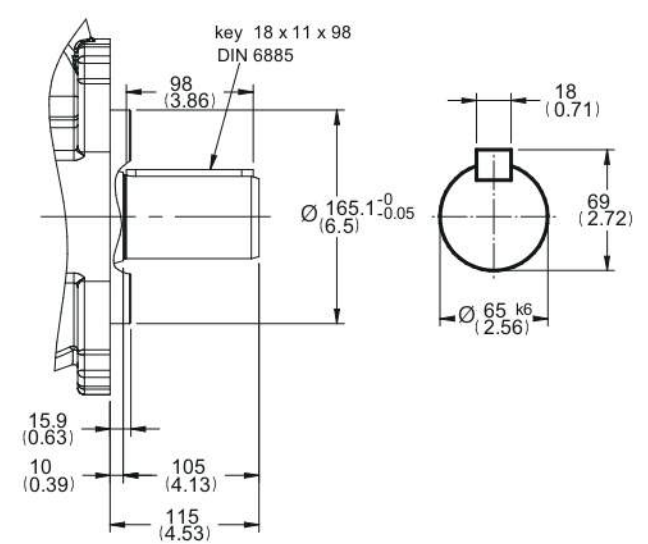

Mounting code: **D**

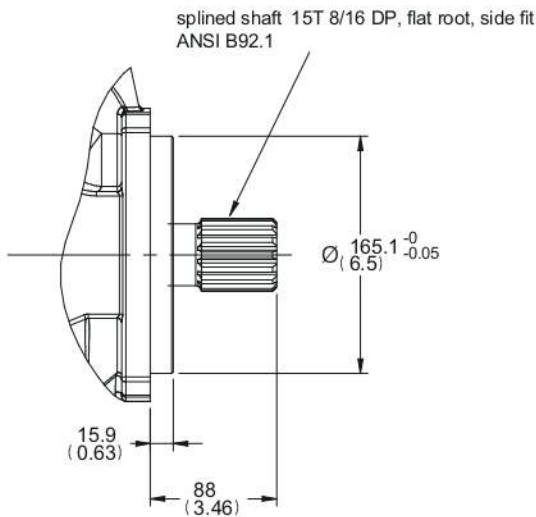

Mounting code: **U**

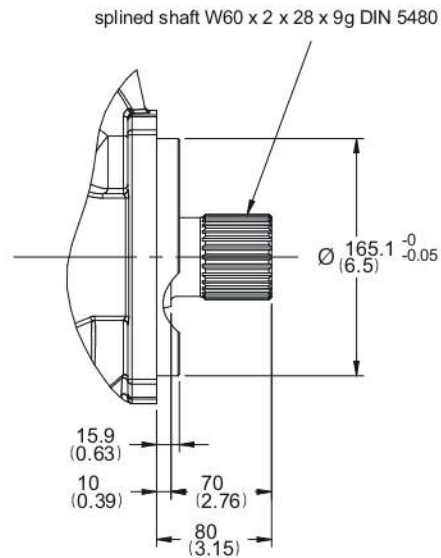



Dimension

PV270 (Body 5)

Thru drive

A

78

PV Axial piston pump

thru drive:

D, E, F, G, H, J, K, L, M, N

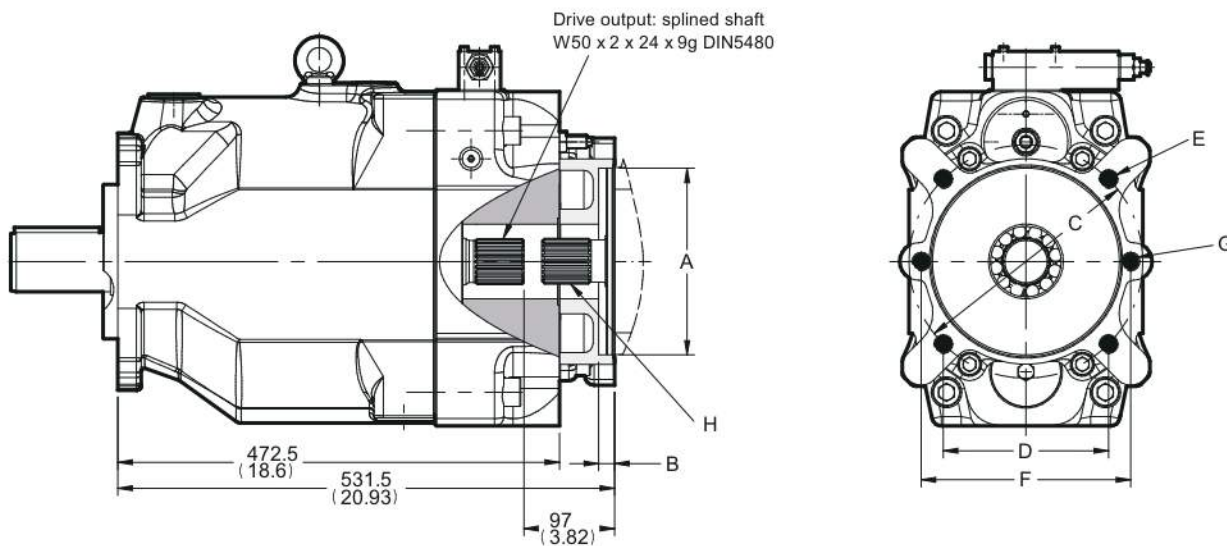

Thru shaft adaptors are available with the following dimensions:

thru code	A	B	C	D	E	F	G
J	80	8.5	103	-	M8	109	M10
K	100	10.5	125	-	M10	140	M12
L	125	10.5	160	-	M12	180	M16
M	160	13.5	200	-	M16	224	M20
N	200	13.5	250	-	M20	n. avail.	n. avail.
D	82.55	8	-	-	-	106	M10
E	101.6	11	-	89.8	M10	146	M12
F	127	13.5	-	114.5	M12	181	M16
G	152.4	13.5	-	161.6	M16	229	M20
H	165.1	17	-	224.5	M20	n. avail.	n. avail.

Thread codes are 3 and 7 the dimensions E and G are UNC-2B threads

threads code: 3 and 7 Not standard, not in stock require special requests.



Dimension

PV270 (Body 5) Inlet / outlet Flange

Thru drive

Inlet Flange

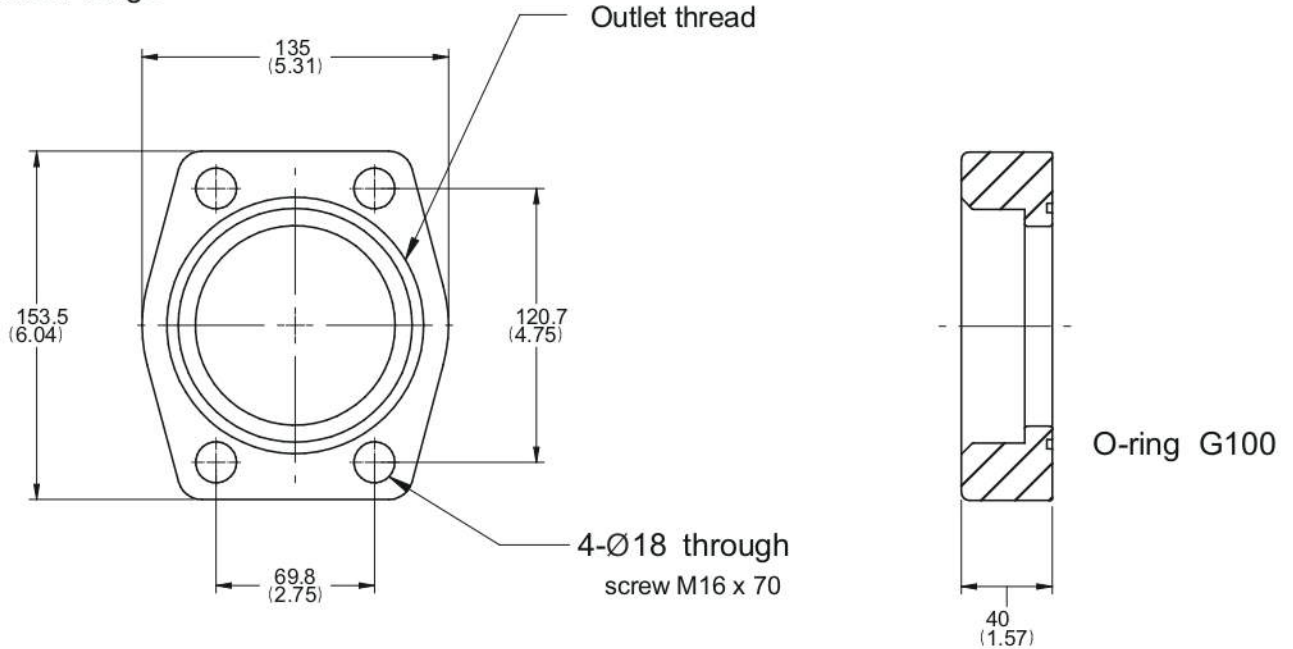

Outlet Flange

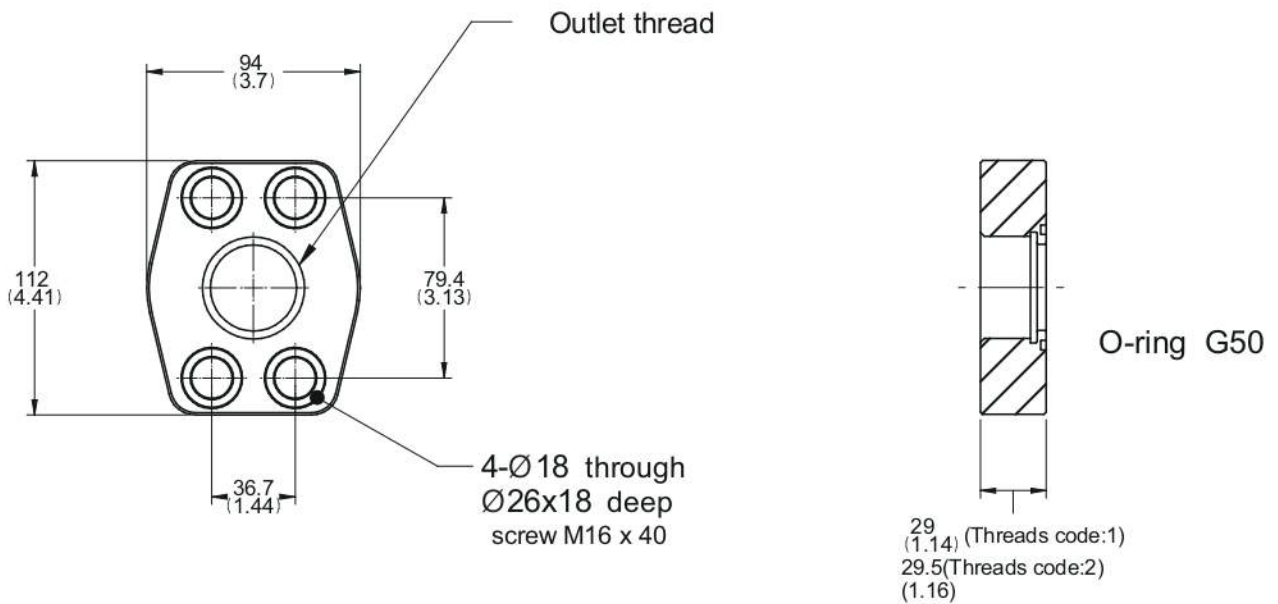

Ports

Thread code	3	1	2	7
	UNF(SAE)	BSPP(G)	PT(RC)	ISO 6149(M)
Inlet	welding 3 1/2"			
Outlet	1 7/8"-12 UN	G 1 1/2"-11	PT 1 1/2"-11	M48*P2.0

Threads code: 3 & 7 are not standard, not it stock, specially fabricate.